

# Chromalox<sup>®</sup>

## Installation, Operation Instructions

### SERVICE REFERENCE

DIVISION 4	SECTION AEPS
SALES REFERENCE (Supersedes PA404-2)	PA404-3
161-562805-001	
DATE	DECEMBER, 2008

## Type AEPS Explosion Proof Strip Heater For: Class I, Div. 1, Groups B, C, D, Environment – Operating Temperature Code T3 or Class I, Div. 1, Groups B, C, D, Class II, Div. 1, Groups E, F, G Environment – Operating Temperature Code T3C

Note: Operating Temp Code T3C-Obsolete 2007

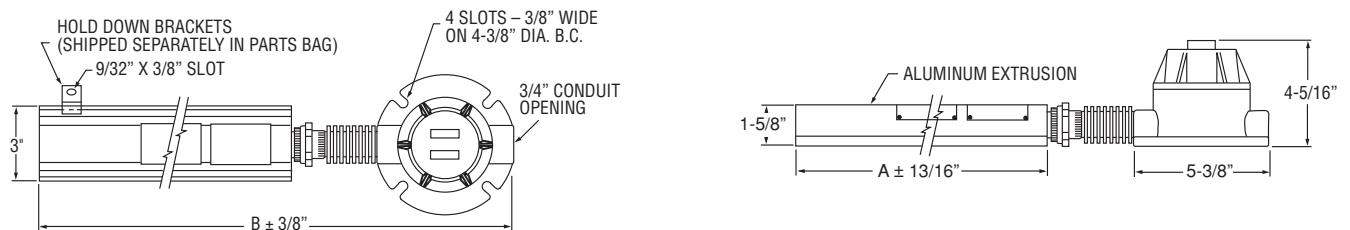

### ⚠ WARNING

**FIRE/EXPLOSION HAZARD.** These heaters must not be operated in ambient temperatures exceeding 40°C (104°F).

### ⚠ WARNING

**FIRE/EXPLOSION HAZARD.** Keep combustible materials at least 12 inches away from extrusion surfaces.

### CATALOG NUMBERS

<b>A E P S - 0 0 0 - 0 0 0 0 - 0 0 0 - 0</b>		
CONSTANT 'A' EXTRUSION LENGTH IN INCHES (024 THRU 120) ('B' = 'A' + 9-1/4")	WATTAGE CODE	NO DIGIT STD. WATTAGE 'W' = REDUCED WATTAGE WATTS/LINEAR INCH (9.17 = 917, 4.58 = 458)

### WATTAGE RATINGS

#### 9.17 W/LINEAR IN. EXTRUSION DANGER – EXPLOSION HAZARD

These heaters are for operation in Class I, Div. 1, Groups B, C, D Hazardous Environments. DO NOT install in an area where gases or vapors having an ignition temperature less than 200°C (392°F) are present.

MAXIMUM WATTAGE EXAMPLE		
'A'	x	W/LINEAR IN. = WATTS
24	9.17	220
120	9.17	1100

#### 4.58 W/LINEAR IN. EXTRUSION DANGER – EXPLOSION HAZARD

These heaters are for operation in Class I, Div. 1, Groups B, C, D and Class II, Div. 1, Groups E, F, G, Hazardous Environments. DO NOT install in an area where gases or vapors having an ignition temperature less than 160°C (320°F) are present.

MAXIMUM WATTAGE EXAMPLE		
'A'	x	W/LINEAR IN. = WATTS
24	4.58	110
120	4.58	550

### VOLTAGE LIMITS VS. EXTRUSION LENGTH

9.17 W/LINEAR IN.	
VOLTS	EXTRUSION LENGTHS
120	24 THRU 53
208	24 THRU 90
240	24 THRU 104
277	24 THRU 120
480	37 THRU 120

4.58 W/LINEAR IN.	
VOLTS	EXTRUSION LENGTHS
120	24 THRU 74
208	24 THRU 120
240	26 THRU 120
277	30 THRU 120
480	51 THRU 120

## GENERAL

Chromalox Type AEPS explosion proof electric strip heaters are ideal for the control of moisture in mechanical conveyor lines, vibrating feeders or other automatic material handling equipment. This heavy-duty strip heater safely prevents freezing of the materials transported.

1. Heater construction characteristics:
  - a. Designed for maximum heat dissipation. Its heavy 3-inch wide aluminum extrusion protects a .475" diameter single end tubular heating element and provides adequate protection against unexpected fusion failures.
  - b. Heater lengths available up to 10 ft. maximum.

- c. Vibration resistant.
- d. All exposed surfaces of the heater are aluminum.

### **⚠ WARNING**

**The system designer is responsible for the safety of this equipment and should install adequate back-up controls and safety devices with their electric heating equipment. Where the consequences of failure could result in personal injury or property damage, back-up controls are essential.**

## INSTALLATION

### **⚠ WARNING**

**ELECTRIC SHOCK HAZARD. Disconnect all power before installing or servicing heater. Failure to do so could result in personal injury or property damage. Heater must be installed or serviced by a qualified person in accordance with the National Electrical Code, NFPA 70.**

1. Before installing, check your strip heater for any damage that may have occurred during shipment.
2. Check to insure that the line voltage is the same as that stamped on the nameplate.
3. Channel in extrusion facilitates mounting to any non-combustible surface. Clamps are supplied or bolt hole can be drilled through groove in extrusion plate.

4. Heaters are furnished with a packet that includes holddown clamps and wire nuts for field wiring. Holddown clamps should be mounted so that the maximum distance between clamps does not exceed 18". The 1/4" bolts (by others) should be tightened and backed off a quarter turn to allow for expansion.

**FIRE HAZARD. Since electric heaters are capable of developing high temperatures, extreme care should be taken to:**

- a. Avoid contact between heaters and combustible materials.
- b. Keep combustible materials far enough away to be free of the effects of high temperatures. (See page 1)

**WARNING:** (Group B): to prevent ignition of Group B atmospheres, conduit runs must not exceed 3/4 inch in size and all conduit runs, 1/2 inch size and larger, must have a sealing fitting connected within 2 inches of the terminal enclosure.

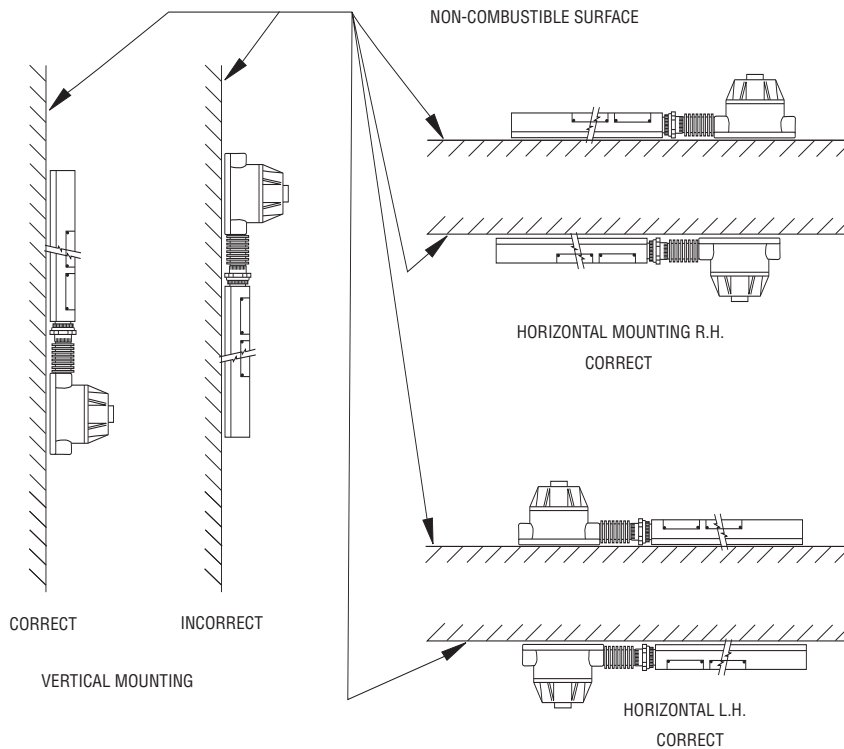

**Vertical Mounting** — When the heater is vertically mounted, the terminal housing must be at the bottom.

**Horizontal Mounting** — When the heater is horizontally mounted, the terminal housing can be positioned L.H. or R.H.

## WIRING

### ⚠ WARNING

**ELECTRIC SHOCK HAZARD. Any installation involving electric heaters must be performed by a qualified person and must be grounded in accordance with the National Electrical Code to eliminate shock hazard.**

1. All wiring should be done in accordance with National Electric Code and with local codes.

2. Connect heaters to same line voltage, phase, and frequency as on heater nameplate.
3. Contactor and 120-240-v control circuit, 125 VA maximum required 208, 240, and 480 volt units. (See Wiring Diagrams)
4. Branch circuit wire for connecting to heater must be at least 90°C wire. Use copper only per NEC.
5. Wiring connections are to be made on designated wire leads as shown in the wiring diagram located inside the enclosure cover and below.

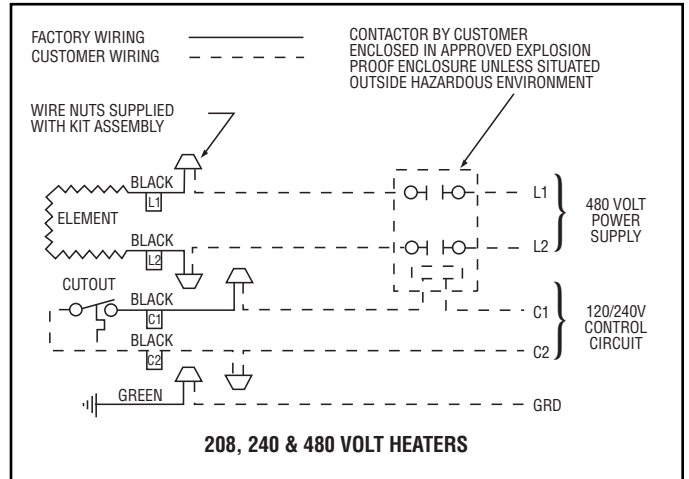
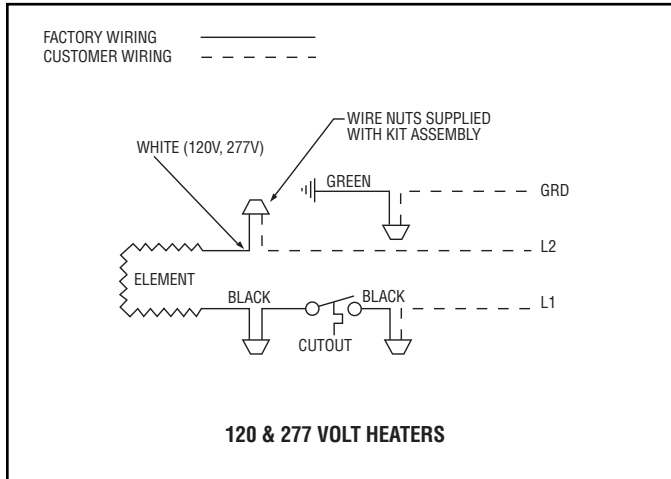

## OPERATION

1. Do not operate heaters at voltages in excess of that stamped on the heater since excess voltage will shorten heater life.
2. These heaters are designed for operation in Hazardous Environment Conditions restricted to those compounds that may be exposed safely to hot spot temperatures as related to specific code symbols per the tabulation on page 1. See "danger plate" on housing for operating temperature range.
3. If the backup limit control (manual reset) functions, disconnect all supply circuits before opening the terminal enclosure. Check to determine cause of limit control functioning.
4. After restoring system to working condition, reset the backup limit control, reassemble terminal cover before energizing the heater. Keep cover tightly closed when in operation.

## MAINTENANCE

### ⚠ WARNING

**FIRE/EXPLOSION HAZARD. To prevent ignition of hazardous atmospheres disconnect all supply circuits before opening terminal enclosures. Keep tightly closed when in operation.**

1. Periodically check all electrical connections and retighten terminals to avoid electrical wiring difficulties.
2. Periodically clean heater surfaces which may accumulate dust and other airborne materials during periods of idleness and whose presence may interfere with efficient heat dissipation from heating surfaces.

## RENEWAL PARTS

**FOR PARTS REPLACEMENT, THE HEATER ASSEMBLY MUST BE RETURNED TO CHROMALOX PRODUCT SERVICE. CONTACT YOUR LOCAL CHROMALOX SALES OFFICE FOR A MATERIAL RETURN AUTHORIZATION.**

**Limited Warranty:**  
Please refer to the Chromalox limited warranty applicable to this product at  
<http://www.chromalox.com/customer-service/policies/termsofsale.aspx>.

**Chromalox<sup>®</sup>**  
**PRECISION HEAT AND CONTROL**  

---

**2150 N. RULON WHITE BLVD., OGDEN, UT 84404**  
**Phone: 1-800-368-2493      [www.chromalox.com](http://www.chromalox.com)**