

1603

Temperature Controller



Issue Date
June 1999

USER'S MANUAL

0037-75214

Contents

Model Identification	Page ii	Manual Reset of Alarms	13
Dimensions and Panel Cut Out	1	SMART Function	14
Wiring	2	Direct Access to Setpoint Modification	15
Thermocouple Inputs	2	Output Power OFF	15
RTD Inputs	3	Lamp Test	15
Relay Outputs	3	1603 Operator Parameters	16
Voltage Output	5	Error Messages	18
Power Line and Grounding	6	Error Descriptions	19
Configuration Procedure	7	Calibration Procedure	21
Advanced Configuration	10	Warranty and Return	26
Operator Mode	12		
Pushbutton Functions	13		

Model Identification

Model

1603 1/16 DIN Temperature Controller, Dual Display

Code Output 1 - Heat or Cool

1 Relay, 3 Amps at 250 Vac (Resistive)

6 SSR Drive, 14 Vdc at 20 mA

Code Output 2 - Cool or Alarm

1 Relay, 1 Amp at 250 Vac (Resistive Load)

Code

0 Add to complete model number

Code Instrument Power

3 100-240 Vac

5 24 Vac/dc

Code

0 Add to complete model number

1603 - 6 1 0 3 0 Typical Model Number

Figure 1
Dimensions and Panel Cut Out

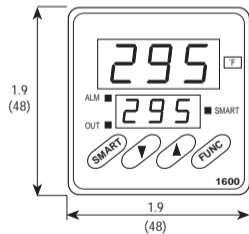
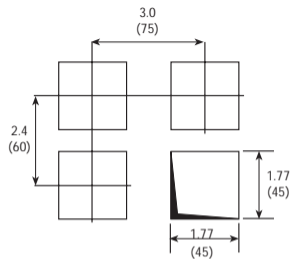
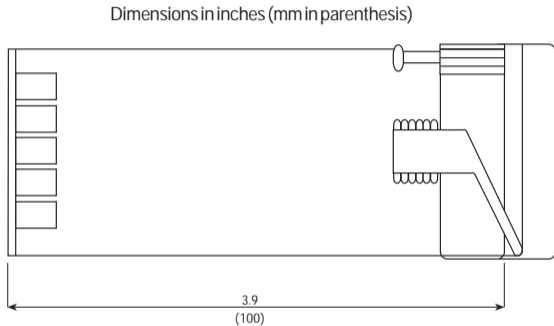
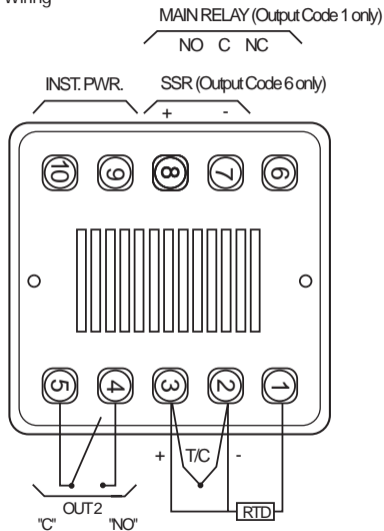

Figure 2
Wiring



Wiring Guidelines

Sensor Inputs

Note:

Any external components (like Zener diodes, etc.) connected between sensor and input terminals may cause errors in measurement due to excessive and/or not balanced line resistance or possible leakage currents.

TC Input

Figure 3

Thermocouple Input Wiring

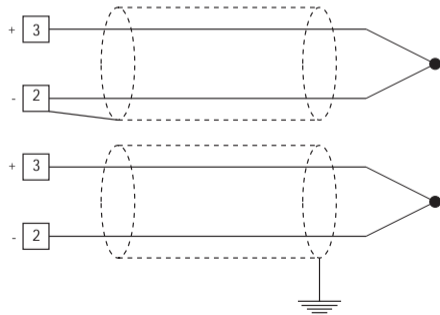

TC Inputs (continued)

Notes:

1. Do not run input wires with power cables.
2. For TC wiring use proper compensating cable (use type J TC extension wire with type J TC connections), preferably shielded.
3. Shielded cable should be grounded at one end only.

RTD Input

Figure 4

RTD Input Wiring

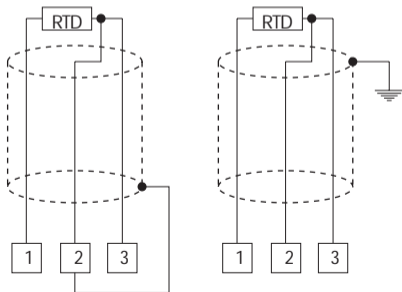

Notes:

1. Do not run input wires together with power cables.
2. Observe the line resistance; a high line resistance may cause measurement errors.
3. When shielded cable is used, it should be grounded at one end only to avoid ground loop currents.
4. The resistance of the 3 wires must be the same.

Relay Outputs

Figure 5

Relay Outputs

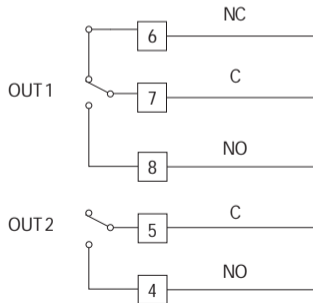

Relay Outputs (continued)

The OUT 1 NO contact and the OUT 2 contact are protected by varistor against inductive loads with inductive components up to 0.5 A.

OUT 1 contact rating is 3A/250Vac resistive load.

OUT 2 contact rating is 1A/250Vac resistive load.

The number of operations is 1×10^5 at specified rating.

Notes:

1. To avoid electric shock, connect power line at the end of the wiring procedure.
2. For power connections use No 16 AWG or larger wires rated for at least 75°C .
3. Use copper conductors only.
4. Do not run input wires together with power cables.

Inductive Loads

Employing the following recommendations will help avoid serious problems that may occur when relay outputs are used with inductive loads.

High voltage transients may occur when switching inductive loads. Through the internal contacts these transients may introduce disturbances that can affect the performance of the controller.

For all the outputs, the internal protection (varistor) assures a correct protection up to 0.5 A of inductive component.

The same problem may occur when a switch is used in series with the internal contacts as shown in Figure 8.

Figure 6

External Switch in Series with the Internal Contact

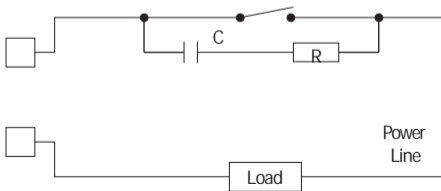

Inductive Loads (continued)

Warnings:

When a relay output is used to drive an inductive load, it is suggested that you connect an external snubber network (RC) across the terminals using Chromalox P/N 0149-01305.

Voltage Outputs for SSR Drive

The SSR Drive Output is a time proportioning output.

Logic Level 0: $V_{out} < 0-5 \text{ Vdc}$

Logic Level 1: $14\text{V} \pm 20\% @ 17\text{mA}$
 $+24\text{V} \pm 20\% @ 1\text{mA}$

Maximum = 17mA

Notes:

1. This output is not isolated. An external solid state relay with 2600V isolation must be used to isolate the controller output and power supply for CE compliance. The Chromalox Series 4115, 7710, 4001, and 4003 meet these isolation requirements.
2. To determine Output #1 output type, check the tag on your controller and compare it to the model identification table on page ii.

Figure 7

SSR Drive Output Wiring

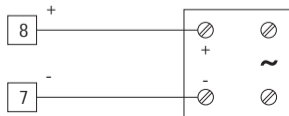

Power Line and Grounding

Figure 8
Power Supply

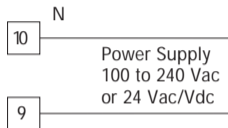

Notes:

1. Before connecting the power line, check that the voltage is correct (see Model Identification, pg. ii).
2. For supply connections use 16 AWG or larger wires rated for at least 75 °C.
3. Use copper conductors only.
4. Do not run input wires with power cables.
5. Polarity does not matter for 24 Vdc wiring.
6. The power supply input is **NOT** fuse protected. Please provide external fusing.

Power supply	Type	Current	Voltage
24 V AC/DC	T	500 mA	250 V
100/240 V AC	T	125 mA	250 V

When the fuse is damaged, it is advisable to verify the power supply circuit. Return the controller to Chromalox for test and verification.

7. Safety requirements for permanently connected equipment:
 - Include a switch or circuit-breaker in the installation.
 - Place the switch in close proximity to the equipment and within easy reach of the operator.
 - Mark the switch as the disconnecting device for the equipment.

Note:

- A single switch or circuit-breaker can drive more than one controller.
8. When the NEUTRAL line is present, connect it to terminal 10.
 9. To avoid shock and possible controller damage, connect power last.

General Operation

There are two setup modes for the 1603:

- Configuration Mode
- Operator Mode

In general, the Configuration Mode is the initial setup of the controller when first installed. Input type and alarm setup are examples of Configuration Mode settings. The Operator Mode includes settings that might be adjusted frequently with daily control operations such as setpoints and PID parameters.

Pushbutton Functionality During Configuration Procedure

FUNC = Must be pressed to store the new value of a selected parameter and increments to the next parameter.

SMART = In configuration Mode, scrolls parameters back (in reverse order) without storing the new parameter value.

- ▲ = Increases the value of the selected parameter .
- ▼ = Decreases the value of the selected parameter.

Configuration Procedure

1. Remove the controller from its case.
2. Set the internal switch V2 (see Fig. 9) in open condition.
3. Reinsert the controller in the case.
4. Switch the controller "ON".
Note: If "CAL" indication is immediately displayed, press the ▲ pushbutton to return to the configuration mode "CnF."
5. Push the FUNC pushbutton. The lower display will show the parameter alphanumeric and the upper display will show the parameter value.

Figure 9

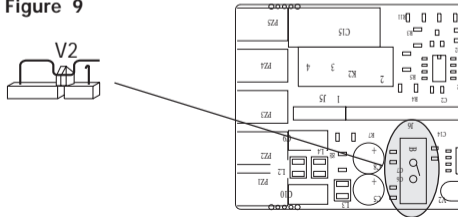

P1 - Input Type and Standard Range

0	= TC type	L	range	0/+800 °C
1	= TC type	J	range	0/+800 °C
2	= TC type	K	range	0/+999 °C
3	= TC type	N	range	0/+999 °C
4	= RTD type	Pt100	range	-199/+500 °C
5	= RTD type	Pt100	range	-19.9/+99.9 °C
6	= TC type	T	range	0/+400 °C
8	= TC type	L	range	0/+999 °F
9	= TC type	J	range	0/+999 °F
10	= TC type	K	range	0/+999 °F
11	= TC type	N	range	0/+999 °F
12	= RTD type	Pt100	range	-199/+999 °F
13	= TC type	T	range	0/+752 °F

Note: To set the display for °C engineering units, place the °C sticker label on the controller faceplate. The label is located in the shipping box.

P2 = Initial Scale Value

Not present when P1 = 5

Enter the initial and full scale values which are going to be used by the PID algorithm to calculate the input span.

When this parameter is modified, rL (setpoint lower limit) is automatically modified to the same value.

P3 = Full Scale Value

Not present when P1 = 5

When this parameter is modified, rH (setpoint upper limit) is automatically modified to the same value. The initial and full scale values determine the input span which is used by the PID algorithm, the SMART and the alarm functions.

Note: The minimum input span (P3 - P2) is 600°F (300°C) for TC input and 200°F (100°C) for RTD input.

P4 = Main Output Action

The 1603 skips this parameter when P5 = 5 (cooling)

r = reverse action (heating)

d = direct action (cooling)

P5 = Output 2 Functions

0 = None

1 = Process alarm (absolute)

2 = Band alarm (+ and - deviation)

3 = Deviation alarm (+ or - deviation)

4 = Controller failure indicator (under- or over-range, CJC or A-D converter failure)

5 = Cooling output

Note: When P5 = 5, the P4 parameter is forced to "r".

P6 = Output 2 Operative Mode

P6 is available only when P5 is different from 0.

When P5 = 1, 2, or 3:

H.A. = high alarm (outside board) with automatic reset

L.A. = low alarm (inside band) with automatic reset

H.L. = high alarm (outside band) with manual reset

L.L. = low alarm (inside band) with manual reset

When p5 = 4, the selections H.A. and L.A. are controller failure indicator alarms with automatic reset. The H.L. and L.L. selections are controller failure indicator alarms with manual reset.

When P5 = 5, this parameter selects the cooling medium:

Air = Air

OIL = Oil

H₂O = Water

Note: Different set of cooling medium produces the automatic modification of the relative cooling gain and of the cooling cycle time.

P6	C (cycle time)	rC (cool gain)
Air	10(s)	1
Oil	4(s)	08
H ₂ O	2(s)	04

P7 = Alarm Action

Present only when P5 is different from 0 or 5.

r = reverse (relay de-energized in alarm condition)

d = direct (relay energized in alarm condition)

P8 = Alarm Inhibit

Present only when P5 is different from 0,4 or 5.

OFF = Inhibit disabled

ON = Inhibit enabled

Note: If the alarm is programmed as band or deviation alarm, this function disables the alarm condition after a setpoint change or at the controller startup until the process variable passes the alarm setpoint plus or minus hysteresis. If the alarm is programmed as a process alarm, this function disables the alarm condition at controller startup until the process variable passes the alarm setpoint plus hysteresis.

P9 = OFFSET Applied to the Measured Temperature

This OFFSET is applied along the whole range.

When P1 = 5 P9 is programmable from -19.9 to 19.9 °C.

When P1 ≠ 5 P9 is programmable from -199 to 199 °C or °F.





P10 = Threshold of the "Soft Start" Function

Enter the Threshold value, in °C or °F, for the automatic start of the "Soft Start" function (limiting output power). If the unit powers up below the Threshold value, the "Soft Start" function is enabled and limits the power output to "OLH" for "tOL" minutes. "OLH" and "tOL" are set in the Operator Mode.

P11 = User Defined Security Code

- 0 = Security lock disabled. All Operator Mode parameters can be modified.
- 1 = Security lock enabled. No parameters can be modified except the setpoint.
- 2 to 499 = Select the security code (to be stored).

During the “Operator Mode” the security code setting will display:

- a.   The controller is “Unlocked” and all parameters can be modified. To make the device Locked,” insert a number different from the security code. Now none of the parameters can be modified except the SP.
- b.   The controller is “locked” and none of the parameters can be modified except the SP. To “Unlock” the device, insert the security code.

500 to 999 = Selecting a security code between these two numbers, everything will occur as explained above except that when the device is “Locked” the only parameters that can be modified are the setpoint and the alarm setpoint.

P12 = Control Output Maximum Rate of Rise
Programmable from 1% to 10% of the output per second. The ramp is applied when the controller changes the percent of output desired. Above 10%, the display will show “InF”, meaning that no ramp is imposed and the output immediately changes to the PID calculated value. P12 not used if ON/OFF control selected.

Advanced Configuration

When the standard configuration procedure is completed, the controller shows “-,-,-,-” on both displays. When it is desired to end the configuration procedure, push the FUNC pushbutton. The display will show “COntF”.

To access the advanced configuration parameter, proceed as follows:

1. using ▲ and ▼ pushbuttons, set the 219 code.
2. push the FUNC pushbutton.

P14 = Display of the Operator Parameters

This parameter is available only if P11 is different from 0.
This parameter allows you to enable/disable the display of the operator parameters.

OFF = parameter cannot be displayed

ON = parameter can be displayed, but not changed

P15 = SMART Function Enabling/Disabling

0 = The SMART function is disabled

1 = The SMART function enabling/disabling is NOT protected by the Security Code (P11).

2 = The SMART function enabling/disabling is protected by the Security Code (P11).

P16 = Maximum Value of the Proportional Band by the SMART Function

This parameter may be programmed from P17 or P18 value to 99.9.

P17 = Minimum Value of the Proportional Band Set by the SMART Function in Heating Control Only

This parameter is present only if P5 is different from 5.
It may be programmed from 1.0% to P16 value.

P18 = Minimum Value of the Proportional Band Set by the SMART Function in Heating/Cooling Control Only

This parameter is present only when P5 is equal to 5.
This parameter may be programmed from 1.5% to P17.

Chromalox 1603 User's Manual

P19 = Automatic Modification of Relative Cooling Gain

This parameter is present only when P5 is equal to 5.
OFF = The SMART function does not modify the "relative cooling gain" parameter.

ON = The SMART function modifies the "relative cooling gain" parameter (rC).

P20 = Minimum Value of Integral Time Set by SMART Function

P20 is programmable from 00.1 (10 seconds) to 02.0 (2 minutes).

P21 = Extension of the Anti-Reset-Windup

Range: from -30 to +30% of the proportional band
Note: A positive value increases the high limit of the anti-reset-windup (over setpoint), while a negative value decreases the low limit of the anti-reset-windup (under setpoint).

End of Advanced Configuration

When the advanced configuration procedure is completed, the controller displays "CnF".

To restart Configuration

Push FUNC to begin the Configuration Mode.

Operator Mode

1. Remove the controller from its case.
2. Set the internal switch V2 in closed condition.

Figure 10

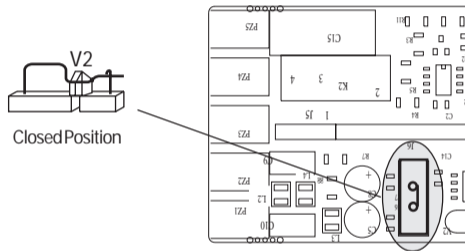

3. Reinsert the controller in its case.
4. If, during the configuration procedure, a display in °C has been selected, it is necessary to put the °C sticker label on the front of the controller. The additional label is located in the shipping box.

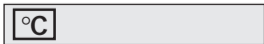

5. The 1603 displays the measured temperature on the upper display and the programmed set point on the lower display. This display is known as the “normal display mode.” **If error 400 message is displayed, press the ▲ or ▼ simultaneously until normal display mode appears.**

Indicators

- SMART** = Flashes when the first part of the SMART algorithm is active. Lit when the second part of the SMART algorithm is active.
- OUT** = Lit when OUT 1 is in ON condition.
- ALM** = Lit when Alarm 1 is in alarm condition or when this output is used as a time proportioning cooling control output.

Pushbutton Functions

FUNC = Must be pressed to store the new value of a selected parameter and increments to the next parameter. Parameter values are displayed on the upper display; parameter name is displayed on the lower display.

SMART = Enables or Disables the SMART function, when held for 1.5 seconds.
Scrolls operator parameters back (in reverse order).

▲ = Increases the value of the selected parameter.

▼ = Decreases the value of the selected parameter.

▼ + **FUNC** = Press together to perform an LED/indicator test. Press both again to turn LED/indicator test “off”.

Note: A 10 second time out occurs during parameter modification. If, during parameter modification, no pushbutton is pressed for more than 10 seconds, the controller automatically reverts to the “normal display mode”. The new setting of the last parameter modified is stored, prior to the time out, only if the FUNC pushbutton was depressed.

Manual Reset of Alarms

If the alarm has been configured as a latching alarm, the alarm status persists after the alarm condition disappears until the alarm is reset.

To reset the alarm, press the FUNC pushbutton to select the “n.rS” parameter. The displays will show “n.rS” and “OFF”. Using ▲ and ▼, select “ON” and push the FUNC pushbutton again.

The alarm reset action will only occur if the alarm condition no longer exists.

SMART Function

The SMART function automatically calculates the optimum PID control parameters. To enable the SMART function, push and hold the SMART pushbutton for more than 1.5 seconds, when the controller is in normal display mode. The SMART LED will light or flash according to the algorithm automatically selected. When the SMART function is enabled, it is possible to display but not to modify the control parameters (PB, TI, TD and rC). When the traditional control (PID) is desired, push and hold the SMART pushbutton for more than 1.5 seconds again to turn the "SMART" OFF. The controller maintains the last set of SMART calculated control parameters and allows parameters to be adjusted.

Notes:

1. During the SMART function operation, the relative cooling gain (if present and controlled by SMART) is limited within the following ranges:

<u>Cooling Medium</u>	<u>Range</u>
Air	0.85 to 1.00
Oil	0.80 to 0.90
H ₂ O	0.30 to 0.60

2. The SMART function uses a derivative time equal to 1/4 of the integral time.
3. The limits of the proportional band set by the SMART function are programmed by P16, P17, and P18 parameters.
4. The lower limit of the integral time set by SMART function is programmed by P20 parameter.
5. When ON/OFF control is programmed (PB = 0), the SMART function is disabled.
6. The SMART enabling/disabling can be protected by the safety lock (see P15 parameter).

Direct Access to Setpoint Modification

When direct access to setpoint modification is required, proceed as follow:

1. Push, for more than 3 seconds, the ▲ or ▼ pushbutton; the set point value, shown on the lower display, will start to change.
2. Using the ▲ and ▼ pushbuttons, set the desired value.
3. When the desired value is reached, do not push any pushbutton for more than 3 seconds. The new setpoint will become operative 3 seconds after the pushbutton is released.

If, during this procedure, there is no interest in memorizing the new value, push the FUNC pushbutton; the controller returns automatically to the normal display mode without having memorized the new setpoint.

Output Power OFF

To turn the output signal OFF, press and hold the ▲ pushbutton then push FUNC.

Pressing both pushbuttons for more than 3 seconds, will cause the controller will show “OFF” instead of the set point value.

In the output power OFF condition, the parameters can always be viewed and modified. When control is disabled (output power off), the alarms are not in an alarm condition. The alarm output status depends on the type of alarm action.

When the output is OFF, all parameters can be reviewed and modified. The SMART function will be disabled during the OFF condition. If power is lost, the unit will power-up in the OFF condition.

To return to normal control, press and hold the ▲ and then push FUNC for more than 3 seconds. The controller then automatically goes to the NORMAL DISPLAY MODE.

The alarm inhibit function, if configured, will be activated as if it were a powerup.

Lamp Test

To verify operation of the display LED, push ▼ and FUNC together. The instrument LEDs will flash until the Lamp Test is turned off.

To turn off the Lamp Test, press ▼ and FUNC together.

No pushbutton functions are operable during the Lamp Test.

1603 Operator Parameters

Push the FUNC pushbutton. The lower display will show the cue while the upper display will show the value of the selected parameter. Not all parameters will be displayed due to specific unit configuration.

<u>Cue</u>	<u>Description</u>
SP	Setpoint—range set at P1-Sensor Selection. May be limited by setting low and high limits at P2 and P3 (see configuration parameters).
nrS	Manual reset of latching alarms. Press ▲ to set ON, then press FUNC to reset the alarm.
nnn	Security code for parameter protection. ON = the controller is in LOCK condition OFF = the controller is in UNLOCK condition When it is desired to switch from LOCK to UNLOCK condition, set a value equal to P11 parameter. When it is desired to switch from UNLOCK to LOCK condition, set a value different from P11 parameter.

<u>Cue</u>	<u>Description</u>
AL	Alarm setpoint—range for a process alarm set at P1-Sensor Selection and may be limited by setting low and high limits at P2 and P3 (see Configuration Parameters). Range for a band alarm 0-500, range for a deviation alarm -199 to 500.
HSA	Alarm hysteresis—deadband range from 0.1 to 10.0 %.
Pb	Proportional band—range from 1.0 to 99.9 % of span (P3-P2) for heat or cool control and 1.5 to 99.9 % of span (P3-P2) for heat/cool control. When Pb = 0 the controller performs as an ON/OFF control and ti, td, C, C2, rC, OLP, OLh and tOL parameters are skipped.
HS	Hysteresis (deadband for ON/OFF control action (Pb = 0)—range from 0.1 to 10 % of input span (P3-P2).
ti	Integral time—range from 0 minutes and 10 seconds to 20 minutes and 0 seconds (minutes, seconds); above the upper limit the display blanks out and the integral action is excluded.
td	Derivative time—range from 0.00 to 9.59

1603 Operator Parameters (continued)

(minutes.seconds). td = 0, turns off derivative action.

<u>Cue</u>	<u>Description</u>
IP	Integral PreLoad—range 0 to 100% for one control output, -100 to 100% for two control outputs (P5 = 5). This parameter does not appear when Pb (Proportional Band) = 0.
C	Heating cycle time—range from 1 to 200 seconds (30 seconds or greater recommended for relay outputs).
C2	Cooling cycle time—range from 1 to 200 seconds (30 seconds or greater recommended for relay outputs). Available if P5 = 5.
rC	Relative cooling gain—range from 0.20 to 1.00. This parameter does not appear if P5 ≠ 5 or PB = 0.
OLP	Dead zone/Overlap—range from -20% to + 50% of the proportional band. A negative value is a dead zone and a positive value creates an overlap. Available if P5 = 5 and PB ≠ 0.
rL	SP low limit—range from the initial scale value (P2) to rH value.

<u>Cue</u>	<u>Description</u>
rH	SP high limit—range from the rL value to the full scale value (P3).
OLH	Output power maximum value—range 0 to 100% heating, -100 to 100% heat/cool, limits power continuously (tOL = Inf) or on start up per tOL setting. PB ≠ 0.
tOL	Time interval for OLH power output limit, range 1 to 100 minutes or if "Inf" infinite. The timer starts on power up if the actual temperature is less than P10 (threshold value). A new TOL value will not become active until the unit is powered up. If PB = 0, this parameter will not be displayed.

Error Messages

OVERRANGE, UNDERRANGE, and BURN-OUT INDICATIONS

The controller shows the OVERRANGE and UNDERRANGE conditions with the following



Overrange



Underrange

indications:

The sensor leads break can be signalled as:

- for TC input: OVERRANGE
- for RTD input: OVERRANGE

Sensor leads short circuit detection:

On RTD input, a special test is provided to signal OVERRANGE when input resistance is less than 15 ohm (short circuit sensor detection).

Note;

- When the controller is set for one output only, and an OVERRANGE is detected, the OUT 1 turns OFF (if reverse action) or ON (if direct action).
- When the controller is set for heating/cooling action, and an OVERRANGE is detected, OUT 1 turns OFF and OUT 2 turns ON.
- When the controller is set for one output only, and an UNDERRANGE is detected, the OUT 1 turns ON (if reverse action) or OFF (if direct action).
- When the controller is set for heating/cooling action, and an UNDERRANGE is detected, OUT 1 turns ON and OUT 2 turns OFF.
- When an OVERRANGE or UNDERRANGE is detected, the alarms operate as in the presence of the maximum or the minimum measurable value respectively.

To eliminate the OUT OF RANGE condition, proceed as follows:

1. Check the input signal source and the connecting line.
2. Make sure that the input signal is in accordance with controller configuration; otherwise, modify the input configuration. See P1.

ERRORS

Diagnostics are made at controller power-up and during normal mode of operation. If a fault condition (error) is detected, the lower display will show the message “Err” while the upper display shows the error code.

ERROR Descriptions

- | | |
|-----|---|
| 100 | EEPROM memory writing error.
After 2 seconds the controller restarts automatically. If this error persists, send the controller back to your supplier. |
| 150 | General hardware error on the CPU card.
If this error persists, send the controller back to your supplier. |
| 200 | Protect register memory error.
The controller remakes this check every 2 seconds.
Set the switch V2 in open condition. Switch on the controller. Set the switch V2 in closed condition, and power the controller.
If this error persists, send the controller back to your supplier. |

ERROR Descriptions

- | | |
|---------|--|
| 201-219 | Wrong configuration parameter value (2xx, where xx is the Configuration Code).
The two least significant digits show the number of the wrong configuration parameter. Return to the configuration procedure and check the values. |
| 301 | RTD calibration error.
Go to calibration procedure and check the P1 and PH calibrations. See RTD calibration check. |
| 305 | Thermocouple input calibration error.
Go to calibration procedure and check the tI and tH calibrations. See Thermocouple Calibration Check. |
| 307 | Reference junction calibration error.
Go to calibration procedure and check the tJ calibration. See Cold Junction Calibration specs. |

ERROR Descriptions

400 One or more control parameters are out of range with respect to the allowed values. It may appear at controller power-up after configuration changes.

Push and hold ▲ and ▼ pushbuttons simultaneously and load all the default parameters.

500 Autozero error.

The controller measures an internal autozero value too negative or too positive. The controller checks this condition every 30 seconds.

If this error persists, send the controller back to your supplier.

502 Cold junction measurement errors.

The controller cannot perform cold junction compensation.

Check the ambient temperature and, if necessary, re-calibrate the cold junction.

If this error persists, send the controller back to your supplier.

ERROR Descriptions

510 Incorrect measured value during calibration procedure.

Check the input value and, if necessary, calibrate the controller.

If this error persists, send the controller back to your supplier.

Calibration

Figure 11

Dip Switch Location: To start calibration, V2 must be OPEN.

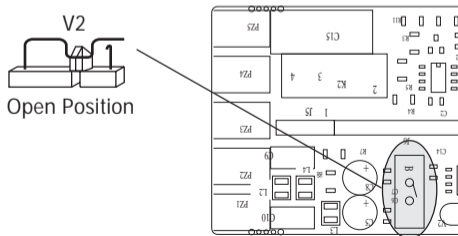

General Guide Lines for Calibration

Note:

All 1603s are calibrated at the manufacturing plant. It is not necessary to calibrate the 1603 on receipt.

For a good calibration, it is necessary to proceed as follows:

1. The controller under calibration should be mounted in its case in order to keep the internal temperature constant.
2. The ambient temperature should be stable. Avoid any draft due to air conditioning, etc.
3. The relative humidity should not exceed 70%.
4. Minimum warm-up time must be 20 minutes.
5. If possible, operate in a noise free environment.
6. During calibration, connect one input at a time to the rear terminal block.

WARNING:

Do not attempt calibration without the recommended simulators or calibrators.

For this calibration procedure it is necessary to use calibrators with the following accuracy and resolution:

Accuracy

1. For TC input: +0.005% output +0.001% range + 5 μ V
2. For RTD Input: $\pm 0.02\% \pm 0.0025 \Omega/\text{decade}$.
3. For cold junction compensation: better than 0.1°C.

Resolution

1. For TC input: 1 μ V.
2. For RTD input: 10 m Ω
3. For cold junction compensation: better than 0.1°C.

Calibration Procedure

Calibration parameters are logically divided in groups of two parameters each (initial and final scale value). After each group, the calibration check is provided but it is also possible to do the check without calibrating.

Note:

Pushing the SMART pushbutton goes back to the previous parameter without modifying the calibration.

Calibration Procedure (continued)

All the controllers are originally calibrated at the factory by means of calibrators with high accuracy and resolution. The following is a complete list of calibration symbols:

<u>Code</u>	<u>Parameter</u>
tL	TC input initial scale value (0 mV)
tH	TC input full scale value (50 mV)
t.	TC input check
rJ	Cold junction compensation
rJ.	Cold junction compensation check
PL	RTD input initial scale value (0 Ω)
PH	RTD input full scale value (300.00 Ω)
P.	RTD input check

How to Proceed

1. To start calibration, V2 must be OPEN (see Figure 11).
2. Switch on the controller. The display will show CnF.
3. Push ▲ pushbutton. The display will show CAL.
4. Push the FUNC pushbutton to display the first calibration code.
5. Depress FUNC pushbutton in sequence until the desired calibration code is reached.

RTD Calibration only:

If only calibrating RTDs, press FUNC until the “PL” parameter is displayed and proceed to page 24 (PL) for further instructions.

TC Input Initial Scale Value

1. Provide connections between calibrator and controller under test as shown in Figure 12.
2. “OFF” will show on the upper display, while “tL” will appear on the lower display.
3. Set calibrator to 0.000 mV. Push ▲ pushbutton. The upper display will change to “ON”.
4. After 30 seconds, start calibration by pushing FUNC pushbutton. Only the decimal point of the last significant digit will light to indicate that the controller is performing the calibration routine. At the end of this calibration routine, the controller will go to the next parameter.

Figure 12

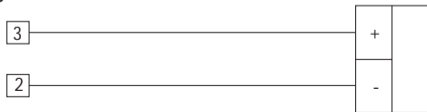

tH-TC Input—Full Scale Value

1. After “tL” is calibrated, the 1603 will display “tH” for the full scale value.
2. Set the calibrator to 50.000 mV (full scale value).
3. Push ▲ pushbutton. The upper display will show “ON”.
4. After 30 seconds, start calibration by pushing the FUNC pushbutton. Only the decimal point of the last significant digit will light to indicate that the controller is performing the calibration routine. At the end of this calibration routine, the controller will go the next step.

TC Input Check

The display will show “t” followed by a number showing the measured value in counts.

With the calibrator set to 50.000 mV, the calibration is correct if the indication is “t.30 000” \pm 10 counts.

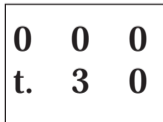

1. Check the zero calibration by setting the calibrator to 0.000 mV. The readout must be t.00 000 \pm 10 counts.
2. Check linearity at half scale by setting 25.000 mV on the calibrator. The readout must be “t 15 000” \pm 10 counts.
3. If linearity is incorrect, repeat thermocouple calibration.
4. Push the FUNC pushbutton. “OFF” and “rJ” will appear on the display.

RJ—Cold Junction Compensation

Note:

Make sure that tL and tH parameters are correctly calibrated before rJ calibration.

1. Measure the temperature close to terminals 1 and 3 using an instrument with accuracy better than 0.1°C (see Figure 13).
2. Wait a few minutes to allow the temperature to stabilize over the entire system.
3. “rJ” and “OFF” are being displayed. Using ▲ and ▼ pushbuttons, set a value equal to the temperature measured by the measuring device in a tenth of °C.

RJ—Cold Junction Compensation (continued)

4. Start calibration by pushing the FUNC pushbutton.
Only the decimal point of the last significant digit will light to indicate that the controller is performing the calibration routine. At the end of this calibration routine, the controller will go to the next calibration step.

Figure 13



Cold Junction Compensation Check

The display will show "rJ." and the temperature, in tenths of °C, measured by the CJ compensator. Make sure that the display readout is equal to the value read on the measuring device. Push the FUNC pushbutton. The controller will go to the next parameter.

TC Calibration only:

Thermocouple calibration is now complete, if RTD calibration is not needed. Press FUNC until "CAL" is displayed. See Step 5 on page 25.

PL—RTD Input Initial Scale Value

1. Connect a resistor box as shown in Figure 14.
2. Set 0.00 Ω on the resistor box.
3. Push \blacktriangle pushbutton. The upper display will show "ON".
4. After 30 seconds, start calibration by pushing FUNC pushbutton. Only the decimal point of the last significant digit will light to indicate that the controller is performing the calibration routine. At the end of this calibration routine, the controller will go to the next parameter.

Figure 14

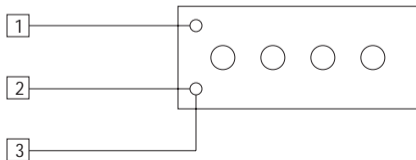

PH—RTD Input Full Scale Value

1. Set the resistance box to 300.00 Ω .
2. Push \blacktriangle pushbutton. The upper display will show “ON”.
3. Wait 30 seconds then push the FUNC pushbutton.
Only the decimal point of the last significant digit will light to indicate that the controller is performing the calibration routine. At the end of this calibration routine. The controller will go to the next parameter.

P.—RTD Input Check

1. The display will show “P.” followed by a number showing the measured value in counts.

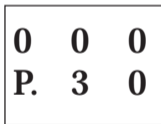

Set the resistance box to 300.00 Ω . The calibration is correct if the indication is “P. 30 000” \pm 10 counts.

2. Check the zero calibration by setting 0.00 Ω on the resistance box. The readout should be “P. 00 000” \pm 10 counts.

3. Check linearity using the table below.

The relationship between input signal and counts for RTD input is not linear.

The correct relationship is shown in the following table:

Resistor Box Ω	Display Counts
0	0 \pm 10 counts
100	10 153 \pm 10 counts
200	20 151 \pm 10 counts
300	30 000 \pm 10 counts

4. If linearity is incorrect, repeat RTD calibration.
5. Push the FUNC pushbutton.

The calibration procedure is terminated and the display will show “CAL”. When it is desired to go to the configuration procedure, depress the \blacktriangle pushbutton and the display will show “CnF” and the controller is in configuration mode.

If the previous configuration is correct, switch the controller OFF and set the switch V2.

Warranty And Limitation Of Remedy And Reliability

Chromalox warrants only that the Products and parts manufactured by Chromalox, when shipped, and the work performed by Chromalox when performed, will meet all applicable specification and other specific product and work requirements (including those of performance), if any, and will be free from defects in material and workmanship under normal conditions of use. All claims for defective or nonconforming (both hereinafter called defective) Products, parts or work under this warranty must be made in writing immediately upon discovery, and in any event, within three (3) years from delivery, however all claims for defective Products and parts must be made in writing no later than three (3) years after shipment by Chromalox. Defective and nonconforming items must be held by Chromalox's inspections and returned to the original f.o.b. point upon request. THE FOREGOING IS EXPRESSLY IN LIEU OF ALL OTHER WARRANTIES WHATSOEVER, EXPRESS, IMPLIED AND STATUTORY, INCLUDING, WITHOUT LIMITATION, THE IMPLIED WARRANTIES OF MERCHANTABILITY AND FITNESS FOR A PARTICULAR PURPOSE.

Notwithstanding the provisions of this WARRANTY AND LIMITATIONS Clause, it is specifically understood that Products and parts not manufactured and work not performed by Chromalox are warranted only to the extent and in the manner that the same are warranted to Chromalox by Chromalox's vendors, and then only to the extent that Chromalox is reasonably able to enforce such a warranty, it being understood Chromalox shall have no obligation to initiate litigation unless buyer undertakes to pay all cost and expenses therefore including but not limited to attorney's fees, and indemnifies Chromalox against any liability to Chromalox's vendors arising out of such litigation.

Upon buyer's submission of a claim as provided above and in its substantiation, Chromalox shall at its option either (i) repair or replace its Products, parts or work at the original f.o.b. point of delivery or (ii) refund an equitable portion of the purchase price.

The foregoing is Chromalox's only obligation and buyer's exclusive remedy for breach of warranty, and is buyer's exclusive remedy against Chromalox for all claims arising hereunder or relating hereto whether such claims are based on breach of contract, tort (including negligence and strict liability) or other theories, buyer's failure to

submit a claim as provided above shall specifically waive all claims for damages or other relief, including but not limited to claims based on latent defects. In no event shall buyer be entitled to incidental or consequential damages and buyer should hold Chromalox harmless therefrom. Any action by buyer arising hereunder or relating hereto, whether based on breach of contract, tort (including negligence and strict liability) or other theories, must be commenced within three (3) years after the date of shipment or it shall be barred.

Returns

Items returned to Chromalox Instruments and Controls must be accompanied by a Return Authorization Number. This number may be obtained from Chromalox Instruments and Controls, Customer Service Department, Telephone Number (615) 793-3900. It should appear on the exterior of the shipping carton and on the shipping documents. Defective items will be repaired or replaced at our option, at no charge.

Return the defective part or product, freight prepaid, to:

Chromalox Instruments and Controls
1382 Heil-Quaker Blvd.
LaVergne, TN 37086-3536

Chromalox[®]

INSTRUMENTS AND CONTROLS

1382 HEIL QUAKER BOULEVARD
LAVERGNE, TN 37086-3536

PHONE (615) 793-3900

FAX (615) 793-3563

WIEGAND INDUSTRIAL DIVISION

EMERSON ELECTRIC CO.

