

LTFX

Electric Tank

Immersion Heaters

Installation Instructions



Chromalox[®]
PRECISION HEAT AND CONTROL

PN403-2
161-049178-101
May 2012

LTFX

Electric Tank Immersion Heater Installation Instructions

General

The Chromalox Electric Tank Immersion Heater, Model LTFX, is an engineered, pretested package designed to give years of virtually maintenance free service and it is shipped ready for installation into a storage tank. LTFX provides low watt-density heating over a large heating surface with precise temperature control for such materials as asphalt, fuel oil, pitch and tar, liquid sugar, lube oils, linseed oil, biodiesel, glycerin, ethanol and many other heat sensitive compounds.

The open coil heating elements (OCE) are housed in either 2" or 3" Schedule 40 carbon or stainless steel pipes, which are welded into the 150# ANSI flange. Once the Unitary Immersion Heater is mated to your tank, the heating elements may be removed and replaced without draining the tank.

Since excessive temperatures may permanently damage the heater and cause premature failure, the use of temperature controls, limiting controls, and liquid level sensors are required.

⚠ WARNING

The system designer is responsible for the safety of this equipment and should install adequate back-up controls and safety devices with their electric heating equipment. Where the consequences of failure could result in personal injury or property damage, back-up controls are essential.

Installation

⚠ WARNING

FIRE OR EXPLOSION HAZARD: The tank must be purged of all flammable vapors prior to cutting or welding.

High heating efficiency, low element temperatures, and longer heater life are achieved when the unit is properly installed.

1. To avoid chipping or cracking, precaution should be taken while unpacking, handling, and installing the ceramic insulators. Heaters with damaged insulators should be returned to the factory for repair or replacement. Contact your local sales office for return authorization.
2. The LTFX unit must not be mounted in the vertical position as the resistance wire on the OCE element can sag, thus causing uneven heating or short circuit. Unit should be installed in a horizontal position with the thermowell on top only.

⚠ WARNING

FIRE OR EXPLOSION HAZARD: Mount the heater in a level, horizontal orientation only. All other orientations may result in property damage or personal injury.

3. IMPORTANT: Mount heater in the tank so the liquid level will always be above the effective heated portion of the heater. Provide expansion tank if necessary.

4. Select a location for this installation according to the following guidelines: (refer to Figure 1)
 - A. Heating elements are removable through the terminal enclosure however adequate room must be provided for this purpose. The removal length of the OCE heating element is 3 feet since the center section may be bent on a 12" radius. OCE elements should only be bent in a vertical plane with ground strap on the bottom.
 - B. The neck on the tank's mating flange should be of adequate length to accommodate tank insulation and flange bolting.
5. Tube supports (internal to the tank) should be placed approximately three feet from the 'wet-side' of the LTFX flange to ensure gasket sealing integrity. Additional tube supports can then be spaced on 10 foot centers. Do not anchor the heater tubes to the supports, as the tubes must be allowed to expand.
6. To ensure proper sealing, a material appropriate gasket needs to be installed between the mating flanges. The mating flanges should then be secured by tightening the bolting according to TEMA Standards.
7. A tank suction pipe should be mounted at least 2" above the level of the heaters. A separate line can be provided to drain tank after heaters have been de-energized.

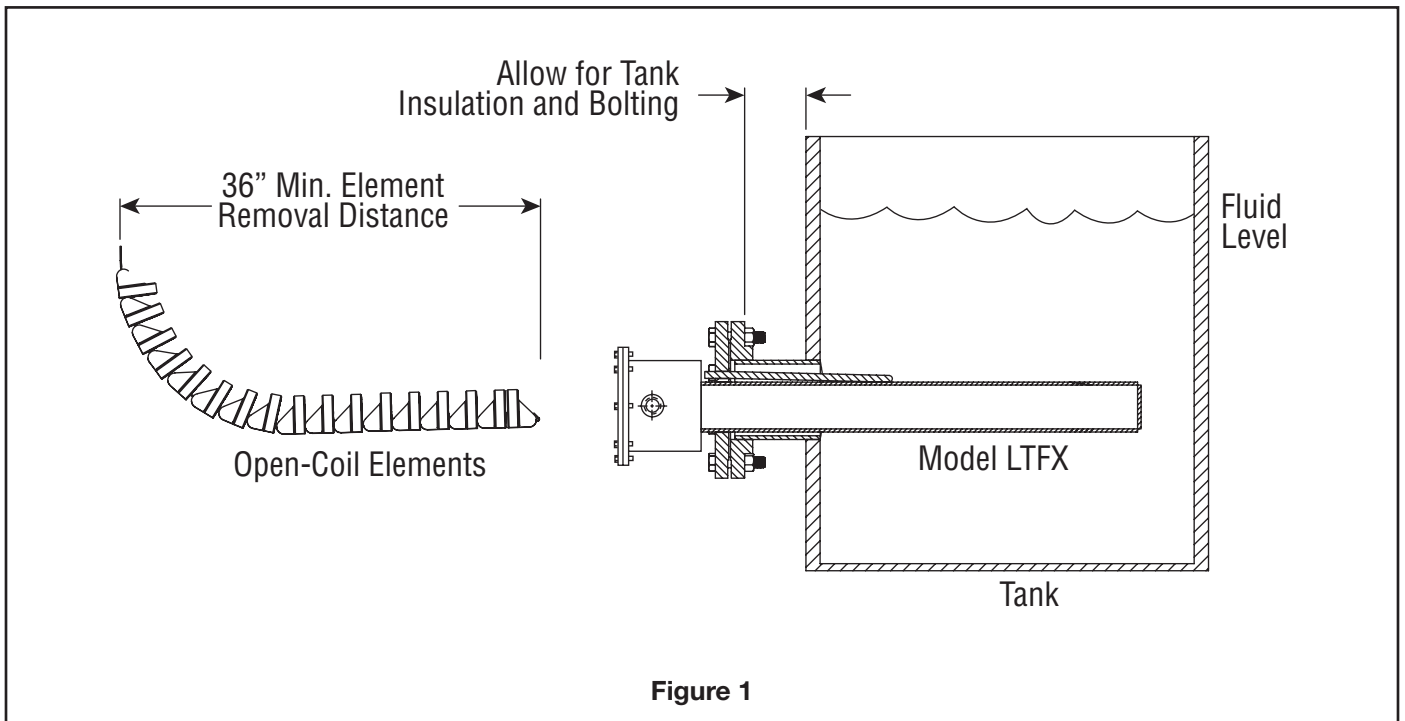

Figure 1

Wiring

⚠ WARNING

ELECTRIC SHOCK HAZARD. Disconnect all power before installing or servicing heater. Failure to do so could result in personal injury or property damage. Heater must be installed or serviced by a qualified person in accordance with applicable National Electric Codes, NFPA 70 and/or International Electric codes.

⚠ WARNING

ELECTRIC SHOCK HAZARD. Any installation involving electric heaters must be performed by a qualified person and must be effectively grounded in accordance with applicable National Electric Codes and/or International Electric Codes to eliminate shock hazard.

⚠ WARNING

The system designer is responsible for the safety of this equipment and should install adequate back-up controls and safety devices with their electric heating equipment. Where the consequences of failure could result in personal injury or property damage, back-up controls are essential.

1. Electrical wiring to heating elements must be sized and installed in accordance with applicable National Electric Codes, International Electric Codes and/or and applicable local codes by a qualified person as defined by the code.
2. Temperatures at the heater terminals will require the use of manganese nickel or equivalent temperature lead wire. (Type TGS, TGT, or TGGT are recommended.)

Wiring Entrance Locations - Moisture Resistant Housing Only (E4 Option)

The Moisture Resistant (E4) Housing offers several convenient options for conduit wiring & location. The housing is equipped with two removable service entrance plates for installation of wiring. Any or all of the six sides can be used for wiring locations. Refer to exploded view drawing. The housing can also be rotated (by removal from flange) to allow for more position possibilities. To install service entrance holes, simply remove the side Allen screws and use the centering depression to drill the appropriate size hole. Reinstall the gasket(s), if applicable, and service entrance plates by tightening the Allen head screws to 4-5 in/lbs. The 'Octobox' style of housing can be removed for ease of access to element bussing or to better locate the power conduit(s) entry point. To accomplish, simply remove the Allen-head screws on the outside of the housing. When reinstalling, be sure to properly align gasket, if applicable, and tighten to 40-50 in/lbs.

Tip for Reinstalling Gaskets:

Place allen head screws through metal covers and gentle push gasket hole over the threaded screw. This will allow the gasket to stay in place while tightening the cover.

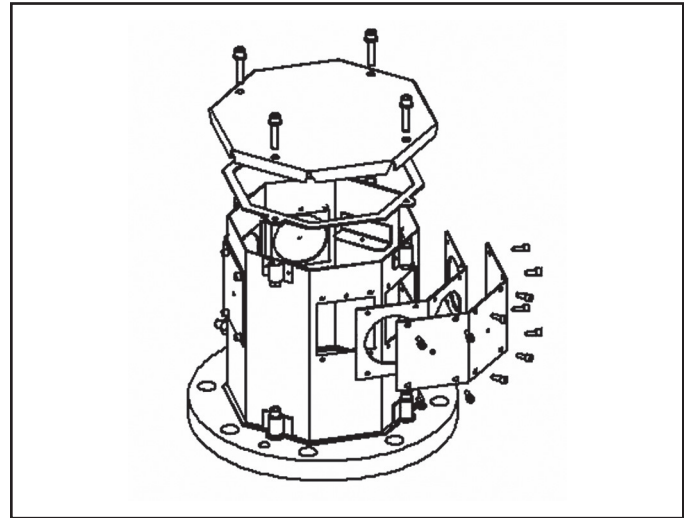

Table A – E4 Wiring Information

| Heater | kW | Volts | Phase | Total Amps | Circuits |
|-----------------|-----|-------|-------|------------|----------|
| LTFX-125-004E4 | 4 | 480 | 3 | 4.8 | 1 |
| LTFX-128-008E4 | 8 | 480 | 3 | 9.6 | 1 |
| LTFX-1212-012E4 | 12 | 480 | 3 | 14.5 | 1 |
| LTFX-2212-024E4 | 24 | 480 | 3 | 28.9 | 1 |
| LTFX-3212-036E4 | 36 | 480 | 3 | 43.4 | 1 |
| LTFX-2325-060E4 | 60 | 480 | 3 | 72.3 | 1 |
| LTFX-3325-090E4 | 90 | 480 | 3 | 108.4 | 3 |
| LTFX-4325-120E4 | 120 | 480 | 3 | 144.5 | 2 |
| LTFX-6325-180E4 | 180 | 480 | 3 | 216.8 | 3 |
| LTFX-8325-240E4 | 240 | 480 | 3 | 289.0 | 4 |

Wiring Entrance Locations - Explosion Resistant Housing Only (E2 Option)

The Explosion Resistant (E2) Housing features dedicated conduit connection sizes and locations for either NPT installation of conduit or Metric cable glands. Incoming wiring must be suitable for a maximum terminal enclosure temperature of 158°F (70°C). Wiring installation must be in accordance with Hazardous Area requirements. The use of EYS seals or rigid conduit may be required. Please consult with the local inspection authority.

Maximum Temperatures

Safe operation in a hazardous location requires the maximum operating temperatures of all exposed surfaces of the heater including temperatures on the outside of the vessel, piping, flanges, screw plugs, enclosures and other heat conducting parts be limited. The flammable liquids, vapors or gases present determine the maximum surface temperature permitted in any hazardous location. The end user or purchaser of the electric heating equipment is responsible for determining the proper classification of an area and for providing Chromalox with hazardous area specifications and requirements for proper equipment design. (NEC and IEC provide guidelines for evaluating and classifying hazardous locations.)

⚠ WARNING





An approved liquid level control or overtemperature control must be installed to deenergize the heater if the liquid level drops below the top of the heater.

Table B – E2 Wiring Information

| Heater | kW | Volts | Phase | Total Amps | Circuits |
|------------------|-----|-------|-------|------------|----------|
| LTFX-125-004E2 | 4 | 480 | 3 | 4.8 | 1 |
| LTFX-128-008E2 | 8 | 480 | 3 | 9.6 | 1 |
| LTFX-1212-012E2 | 12 | 480 | 3 | 14.5 | 1 |
| LTFX-3210-024E2 | 24 | 480 | 3 | 28.9 | 1 |
| LTFX-3215-036E2 | 36 | 480 | 3 | 43.4 | 1 |
| LTFX-3225-060E2 | 60 | 480 | 3 | 72.3 | 1 |
| LTFX-4225-090E2 | 90 | 480 | 3 | 108.4 | 2 |
| LTFX-8215-120E2 | 120 | 480 | 3 | 144.5 | 2 |
| LTFX-9220-180E2 | 180 | 480 | 3 | 216.8 | 3 |
| LTFX-12225-240E2 | 240 | 480 | 3 | 289.0 | 4 |



Third Party Certifications

E4 Moisture Resistant Enclosure Certifications

| | North American Designations (s) | Canadian Designation(s) | European Designation(s) | International Designation(s) |
|-----------|--|---|--|------------------------------|
| Rating | NEMA 4 | NEMA 4 | IP66 | IP66 |
| Agency(s) |   |  |  Manufacturers Declaration | Manufacturers Declaration |



E2 Moisture Resistant Enclosure Certifications

| | North American Designations (s) | Canadian Designation(s) | European Designation(s) | International Designation(s) |
|--------------------|--|---|---|------------------------------|
| Rating | Explosion Resistant | Explosion Resistant | Explosion Resistant | Explosion Resistant |
| Agency(s) | CSAus | CSA | ATEX | IECEX |
| Ratings | Class I, Div. 1 Groups B, C & D | Class I, Div. 1 Groups B, C & D |   0359 II 2 G Ex d IIB+H2 Gb T1 to T6 | Ex d IIB+H2 Gb T1 to T6 |
| | Class II, Div. 1 Groups E, F & G | Class II, Div. 1 Groups E, F & G | IP66 | IP66 |
| | Class I Zone 1 AEx d IIB + H2 Gb T1 to T6 | Class I Zone 1 Ex d IIB + H2 Gb T1 to T6 | | |
| -50°C < Ta < +60°C | | | | |



Operation

⚠ WARNING

FIRE OR EXPLOSION HAZARD. To avoid possible damage to the heater, do not energize until the tank is filled with fluid. Recommended fluid level is 2" above the heater tube or pipe.

⚠ WARNING

FIRE or EXPLOSION HAZARD. Do not open enclosure when energized. Do not open enclosure when an explosive gas atmosphere is present.

1. Do not operate heaters at voltages in excess of that stamped on the heater, since excess voltage will shorten heater life.

2. Heaters should not be operated in environments with factors that can destroy the electrical insulating characteristics of the ceramic insulators. Foreign contaminants can create leakage (shock) hazards, permanent heater damage, or cause heater failure and therefore should be avoided.

For initial operation and tuning the control scheme:

1. Turn the master circuit breaker off and open the control box door.
2. Set the indicating temperature control at the desired temperature and the over-temperature cutout at 50°F above this temperature.
3. Interlock the liquid level control with the cutout device.
4. Close the control box door and turn the circuit breaker on. To energize the heater circuits, turn the on-off selector switch to the "on" position.

Maintenance

⚠ WARNING

FIRE or EXPLOSION HAZARD. Do not open enclosure when energized. Do not open enclosure when an explosive gas atmosphere is present.

⚠ WARNING

ELECTRIC SHOCK HAZARD. Disconnect all power before installing or servicing heater. Failure to do so could result in personal injury or property damage. Heater must be installed or serviced by a qualified person in accordance with applicable National Electric Codes, NFPA 70, and/or International Electric Codes.

1. Make certain both the terminals and the ceramic insulators are free from contact with oil, liquid, or other foreign matter. **NOTE:** Chromalox cannot be responsible for failures or damage caused by contamination on the ceramic insulators. Make certain the heaters are not exposed to contaminants.
2. Check electrical connections at heater terminals and tighten if necessary. This will help avoid hot terminals which may destroy wire insulation or heater terminals
3. Check overheat operation to assure heater protection.

Element Replacement - Moisture Resistant Housing Only (E4 Option)

1. To remove the OCE heating elements, first turn the circuit breaker to the off position.
2. Next remove the housing lid, element wiring and the element mounting screw. Now pull the element straight out of the heating tube. **NOTE:** OCE elements should only be bent in a vertical plane with ground strap on the bottom.

3. When removing the heating elements, make certain that the terminals and the ceramic insulators do not contact oil or any other liquid foreign matter. **Note:** Chromalox cannot be responsible for failures or damage caused by contamination on the ceramic insulators.
4. Installation is the reverse of the above.

Element Replacement - Hazardous Locations, Explosion Resistant Housing Only (E2 option)

1. To remove the OCE heating assembly, first turn the circuit breaker to the off position.
2. Next remove the housing lid, element wiring, and 8mm bolting around the element flamepath module. If bolts must be replaced, use a minimum of grade 10.9. If needed, (2) 1/4-20x2" bolts may be used to break loose the module from the flange. Turn bolts evenly until module is free. The flamepath module will be re-used, so disconnected the heating element from the module pins. Now pull the element assembly out of the heating tube. **NOTE:** OCE elements should only be bent in a vertical plane with ground strap on the bottom.
3. When removing the heating elements, make certain that the terminals and the ceramic insulators do not contact oil or any other liquid foreign matter. **Note:** Chromalox cannot be responsible for failures or damage caused by contamination on the ceramic insulators.
4. Inspect the element assembly flange and mating surface for any debris, oils, or contamination. **NOTE:** Surfaces must be in suitable condition to ensure proper hazardous rating.
5. Connect the new element to the flamepath module and slide into tube. Flamepath module bolting must be tightened to 26 ft/lbs. of torque.
6. Reattach element wiring. When reinstalling housing lid, be sure to properly align gasket, and tighten housing bolts to 26 ft/lbs.

Renewal Parts Identification

Table C – E4 Housing Renewal Parts Identification

| Heater Model | kW | Volts | Phase | Immersion Length In. (mm) | ANSI Flange Size | Number of Tubes | Tube Dia. In. (mm) | OCE Element No. | Replacement OCE Model No. |
|-----------------|-----|-------|-------|---------------------------|------------------|-----------------|--------------------|-----------------|---------------------------|
| LTFX-125-004E4 | 4 | 480 | 3 | 60 | 4" - 150# | 1 | 2" (50.8) | #1 | OCE-05040-2-483 |
| LTFX-128-008E4 | 8 | 480 | 3 | 96 | 4" - 150# | 1 | 2" (50.8) | #2 | OCE-06080-2-483 |
| LTFX-1212-012E4 | 12 | 480 | 3 | 144 | 4" - 150# | 1 | 2" (50.8) | #3 | OCE-12120-2-483 |
| LTFX-2212-024E4 | 24 | 480 | 3 | 144 | 6" - 150# | 2 | 2" (50.8) | #3 | OCE-12120-2-483 |
| LTFX-3212-036E4 | 36 | 480 | 3 | 144 | 6" - 150# | 3 | 2" (50.8) | #3 | OCE-12120-2-483 |
| LTFX-2325-060E4 | 60 | 480 | 3 | 300 | 8" - 150# | 2 | 3" (76.2) | #4 | OCE-25300-3-483 |
| LTFX-3325-090E4 | 90 | 480 | 3 | 300 | 10" - 150# | 3 | 3" (76.2) | #4 | OCE-25300-3-483 |
| LTFX-4325-120E4 | 120 | 480 | 3 | 300 | 10" - 150# | 4 | 3" (76.2) | #4 | OCE-25300-3-483 |
| LTFX-6325-180E4 | 180 | 480 | 3 | 300 | 12" - 150# | 6 | 3" (76.2) | #4 | OCE-25300-3-483 |
| LTFX-8325-240E4 | 240 | 480 | 3 | 300 | 14" - 150# | 8 | 3" (76.2) | #4 | OCE-25300-3-483 |

Table D – E2 Housing Renewal Parts Identification

| Heater Model | kW | Volts | Phase | Immersion Length In. (mm) | ANSI Flange Size | Number of Tubes | Tube Dia. In. (mm) | OCE Element No. | Replacement OCE Model No. |
|------------------|-----|-------|-------|---------------------------|------------------|-----------------|--------------------|-----------------|---------------------------|
| LTFX-125-004E2 | 4 | 480 | 3 | 60 | 4" - 150# | 1 | 2" (50.8) | #1 | OCE-05040-2-483 |
| LTFX-128-008E2 | 8 | 480 | 3 | 96 | 4" - 150# | 1 | 2" (50.8) | #2 | OCE-06080-2-483 |
| LTFX-1212-012E2 | 12 | 480 | 3 | 144 | 4" - 150# | 1 | 2" (50.8) | #3 | OCE-06080-2-483 |
| LTFX-3210-024E2 | 24 | 480 | 3 | 120 | 8" - 150# | 3 | 2" (50.8) | #2 | OCE-06080-2-483 |
| LTFX-3215-036E2 | 36 | 480 | 3 | 180 | 8" - 150# | 3 | 2" (50.8) | #3 | OCE-06080-2-483 |
| LTFX-3225-060E2 | 60 | 480 | 3 | 300 | 8" - 150# | 3 | 2" (50.8) | #5 | OCE-25200-2-4803 |
| LTFX-4225-090E2 | 90 | 480 | 3 | 300 | 10" - 150# | 4 | 2" (50.8) | #6 | OCE-25225-2-4803 |
| LTFX-8215-120E2 | 120 | 480 | 3 | 180 | 12" - 150# | 8 | 2" (50.8) | #7 | OCE-15150-2-4803 |
| LTFX-9220-180E2 | 180 | 480 | 3 | 240 | 14" - 150# | 9 | 2" (50.8) | #5 | OCE-25200-2-4803 |
| LTFX-12225-240E2 | 240 | 480 | 3 | 300 | 14" - 150# | 12 | 2" (50.8) | #5 | OCE-25200-2-4803 |

Limited Warranty:

Please refer to the Chromalox limited warranty applicable to this product at <http://www.chromalox.com/customer-service/policies/termsofsale.aspx>.

Chromalox[®]
PRECISION HEAT AND CONTROL

2150 N. RULON WHITE BLVD., OGDEN, UT 84404
Phone: 1-800-368-2493 www.chromalox.com