

Chromalox®

Installation, Operation and RENEWAL PARTS IDENTIFICATION

SERVICE REFERENCE	
DIVISION 4	SECTION NWHO
SALES REFERENCE (Supersedes PE429)	PE429-1
161-058065-001	
DATE	FEBRUARY, 1986

Type NWHO-45, 72, 108 Circulation Heaters for Regular and Fuel Oil Heating

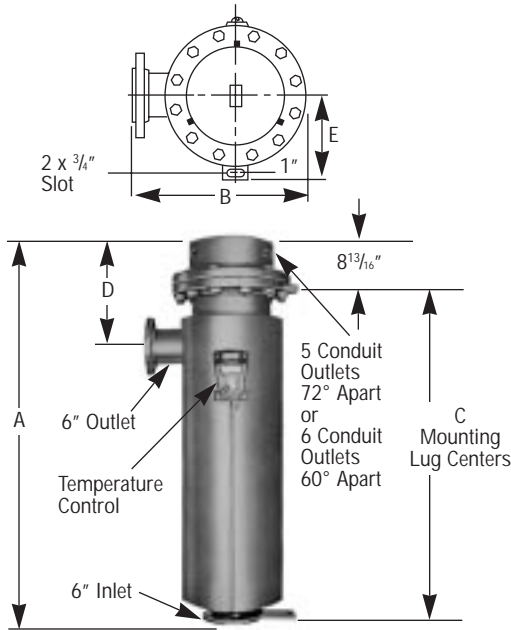

Specifications – Table A

Model	Volts 3Ø	kW	No. 3Ø Circuits	Dimensions (In.)				
				A	B	C	D	E
NWHO-4590	240 or 480	90	5	72 ¹ / ₂	25 ¹ / ₂	63 ⁵ / ₁₆	18 ¹³ / ₁₆	12 ¹ / ₂
NWHO-45125	240 or 480	125	5	87 ¹ / ₂	25 ¹ / ₂	78 ⁵ / ₁₆	18 ¹³ / ₁₆	12 ¹ / ₂
NWHO-45150	240 or 480	150	5	102 ¹ / ₂	25 ¹ / ₂	93 ⁵ / ₁₆	18 ¹³ / ₁₆	12 ¹ / ₂
NWHO-45175	240 or 480	175	5	117 ¹ / ₂	25 ¹ / ₂	108 ⁵ / ₁₆	18 ¹³ / ₁₆	12 ¹ / ₂
NWHO-45200	240 or 480	200	5	125	25 ¹ / ₂	116 ¹ / ₁₆	18 ¹³ / ₁₆	12 ¹ / ₂
NWHO-77220	240 or 480	200	6	97 ¹ / ₂	27 ³ / ₄	88 ⁵ / ₁₆	19	13 ³ / ₄
NWHO-77225	240 or 480	225	6	105 ¹ / ₂	27 ³ / ₄	96 ⁵ / ₁₆	19	13 ³ / ₄
NWHO-77250	240 or 480	250	6	113 ¹ / ₂	27 ³ / ₄	104 ⁵ / ₁₆	19	13 ³ / ₄
NWHO-108300	240 or 480	300	6	98 ¹ / ₂	29 ¹ / ₂	89 ⁵ / ₁₆	19 ³ / ₈	14 ¹ / ₂
NWHO-108325	240 or 480	325	6	104 ¹ / ₂	29 ¹ / ₂	95 ⁵ / ₁₆	19 ³ / ₈	14 ¹ / ₂
NWHO-108350	240 or 480	350	6	110 ¹ / ₂	29 ¹ / ₂	101 ¹ / ₁₆	19 ³ / ₈	14 ¹ / ₂

These Dimensions are typical. Check factory for dimensions of a particular unit.

GENERAL

The high capacity NWHO-45, 72 or 108 series are intended for indoor use and are used primarily for oil heating.

The 45, 72 or 108 steel sheathed tubular elements are centered in a 14", 16" or 18" diameter steel heating chamber, respectively, and welded to a removable steel flange. The assembly is surrounded by 2" of insulation and a sheet metal jacket.

Depending upon the order specifications, the NWHO-45, 72 or 108 may or may not be factory equipped with an MF2 or other Chromalox thermostat. Such thermostats function to control outlet

temperatures and to limit internal temperatures under abnormal flow conditions. These controls do not fail-safe.

CAUTION: Users should install adequate back-up controls and safety devices with their electric heating equipment. Where the consequences of failure may be severe, back-up controls are essential. Although the safety of the installation is the responsibility of the user, Chromalox will be glad to make equipment recommendations.

INSTALLATION

1. Vertical mounting (axis of chamber vertical) is preferred. Check factory for constructions suitable for horizontal mounting.
2. Mount heater with terminal enclosure at top, and use lower nozzle as inlet to the circulating fluid.
3. The NWHO-45, 72 and 108 series of circulation heaters are provided with mounting lugs to support the heater chamber. Refer to Figure A for one suggested mode of support.
4. Mount heaters to permit unrestrained expansion of chamber due to temperature. The large flange lug

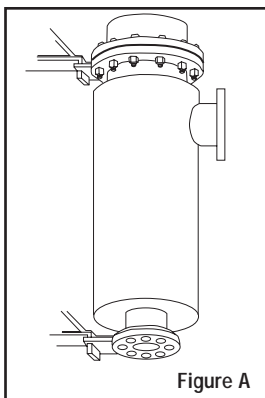

5. DANGER: *Hazard of Fire.* Provide minimum of 6" spacing from chamber and related piping to nearest combustible material. Avoid operation of heater near combustible fluids or in combustible vapor or gas laden atmosphere. **Note:** Contact factory for heaters suitable for use in hazardous locations.
6. Provide adequate space at terminal end to permit withdrawal of the heater from chamber should servicing be required.
7. If two or more heaters are needed to provide the needed heating capacity, arrange them for series flow.
8. DANGER: *Possible Explosion.* A pressure relief valve should be provided by customer at outlet of vessel. There should be no valving between vessel and relief valve.

WIRING

CAUTION: Hazard of Electric Shock. Any installation involving electric heaters must be grounded to earth to eliminate shock hazard.

1. Electric wiring to heater must be installed in accordance with National Electrical Code and with local codes.
2. Because of high operating temperatures expected, aluminum wiring is not recommended.
3. Refer to Wiring Diagram Figure B for the typical wiring used for connecting the NWHO-45 series heater.
4. Three 3 phase circuits is a typical design for these heaters. Other circuit arrangements are often supplied depending upon customer specifications or amperage rating.

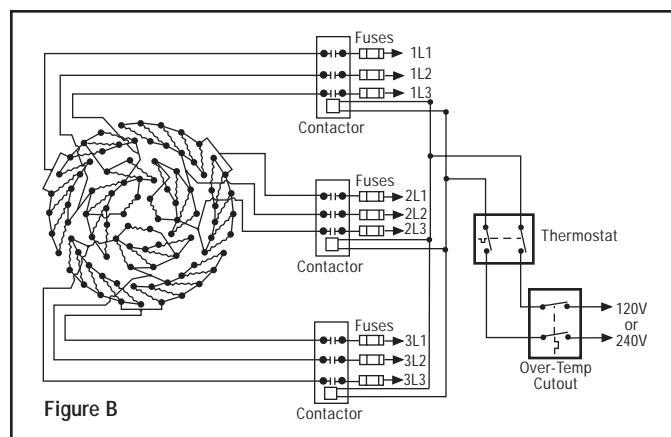

OPERATION

1. Do not heat materials that are corrosive to the heating element sheath or chamber.

WARNING: Type NWHO Circulation Heaters are equipped with steel heating elements and galvanized-steel heating chambers. It is the responsibility of the user to know the chemical composition of the corrosive solution and the character of the materials entering the solution as well as the corrosive effect of the solution upon the heating elements and chamber. Chromalox cannot warrant any electric circulation heater against failure by

sheath corrosion if such failure is the result of operating conditions beyond our control.

2. Terminal ends of heater must be protected from drippings, condensation, spray or direct spill-over of material whose presence at the terminals may damage heater electrical insulation. Liquid-tight terminal enclosures are available to protect heater. Check Factory.
3. If foreign material is carried by the fluid flow, install suitable filters in the inlet pipe line to the heater.
4. Do not allow heater to operate when oil flow is interrupted.

MAINTENANCE

1. **CAUTION: Hazard of Electric Shock.** Disconnect all power before servicing heater.
2. Remove heating element assembly periodically to check heater sheath for corrosion or excessive oxidation. Correct operating conditions to minimize sheath deterioration.
3. Periodically check temperature control and pressure-tempera-

ture safety limit control operation to insure accurate and safe process operation.

4. Check all electrical connections periodically and retighten connections which may have loosened in service. Replace wire and wire terminals which show signs of oxidation which would interfere with establishment of reliable electrical connections.

RENEWAL PARTS IDENTIFICATION

Order Renewal Parts on a Special Order Basis. Give the name of the part, part number, voltage, wattage and any special features

to your local Chromalox Representative or the factory.

WARRANTY AND LIMITATION OF REMEDY AND LIABILITY

Chromalox warrants only that the Products and parts manufactured by Chromalox, when shipped, and the work performed by Chromalox when performed, will meet all applicable specification and other specific product and work requirements (including those of performance), if any, and will be free from defects in material and workmanship under normal conditions of use. All claims for defective or nonconforming (both hereinafter called defective) Products, parts or work under this warranty must be made in writing immediately upon discovery, and in any event, within one (1) year from delivery, provided, however all claims for defective Products and parts must be made in writing no later than eighteen (18) months after shipment by Chromalox. Defective and nonconforming items must be held for Chromalox's inspections and returned to the original f.o.b. point upon request. THE FOREGOING IS EXPRESSLY IN LIEU OF ALL OTHER WARRANTIES WHATSOEVER, EXPRESS, IMPLIED AND STATUTORY, INCLUDING, WITHOUT LIMITATION, THE IMPLIED WARRANTIES OF MERCHANTABILITY AND FITNESS FOR A PARTICULAR PURPOSE.

Notwithstanding the provisions of this WARRANTY AND LIMITATION Clause, it is specifically understood that Products and parts not manufactured and work not performed by Chromalox are warranted only to the extent and in the manner that the same are warranted to Chromalox by Chromalox's vendors, and then only to the extent that Chromalox is reasonably able to enforce such warranty, it being understood Chromalox shall have no obligation to initiate litigation unless Buyer undertakes to pay all cost and expenses therefor, including but not limited to attorneys' fees, and indemnifies Chromalox against any liability to Chromalox's

vendors arising out of such litigation.

Upon Buyer's submission of a claim as provided above and its substantiation, Chromalox shall at its option either (i) repair or replace its Products, parts or work at the original f.o.b. point of delivery or (ii) refund an equitable portion of the purchase price.

THE FOREGOING IS CHROMALOX'S ONLY OBLIGATION AND BUYER'S EXCLUSIVE REMEDY FOR BREACH OF WARRANTY, AND IS BUYER'S EXCLUSIVE REMEDY AGAINST CHROMALOX FOR ALL CLAIMS ARISING HEREUNDER OR RELATING HERETO WHETHER SUCH CLAIMS ARE BASED ON BREACH OF CONTRACT, TORT (INCLUDING NEGLIGENCE AND STRICT LIABILITY) OR OTHER THEORIES, BUYER'S FAILURE TO SUBMIT A CLAIM AS PROVIDED ABOVE SHALL SPECIFICALLY WAIVE ALL CLAIMS FOR DAMAGES OR OTHER RELIEF, INCLUDING BUT NOT LIMITED TO CLAIMS BASED ON LATENT DEFECTS. IN NO EVENT SHALL BUYER BE ENTITLED TO INCIDENTAL OR CONSEQUENTIAL DAMAGES AND BUYER SHALL HOLD CHROMALOX HARMLESS THEREFROM. ANY ACTION BY BUYER ARISING HEREUNDER OR RELATING HERETO, WHETHER BASED ON BREACH OF CONTRACT, TORT (INCLUDING NEGLIGENCE AND STRICT LIABILITY) OR OTHER THEORIES, MUST BE COMMENCED WITHIN ONE (1) YEAR AFTER THE DATE OF SHIPMENT OR IT SHALL BE BARRED.

W2008M

Chromalox[®]
PRODUCT SERVICE
 600 RIDGELY ROAD, MURFREESBORO, TN 37129
 PHONE: (615) 848-2565 FAX: (615) 848-2181

WIEGAND INDUSTRIAL DIVISION
 EMERSON ELECTRIC CO.

