

Chromalox®

PRECISION HEAT AND CONTROL



SUBMITTAL SHEET CVEP EXPLOSION PROOF CONVECTORS

Capacities

**1.6, 1.8, 3.2, 3.6, 4.0, 7.6 , 9.0
kW
208, 240, 480, 575V
1Ø or 3Ø**

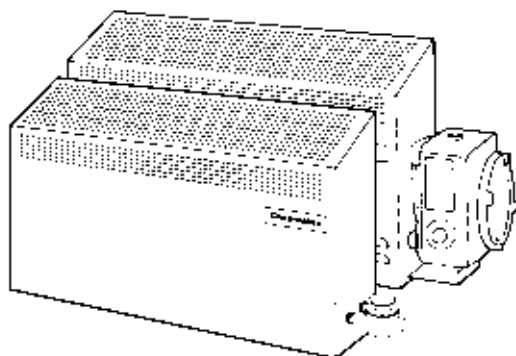

See Selection Chart
Back Page

Approved for Division 1 & 2
Class I - Group B, C & D

JOB NAME: _____

LOCATION: _____

ARCHITECT: _____

ENGINEER: _____

CONTRACTOR: _____

SUBMITTED BY: _____

DATE: _____

QTY.	MODEL NUMBER	TAG	HEATER			AMPS	BUILT-IN CONTROLS
			KW	VOLTS	Ø		

ACCESSORIES
AND
CONTROLS

QTY.	MODEL NO.	TAG	DESCRIPTION

Sample Specifications

1 General

- 1.1 The Explosion-Proof Convection Air Heater Model Number _____ Rated _____ Volts, _____ Phase, _____ Watts, shall be designed and constructed for use in hazardous locations.
- 1.2 For Groups B, C and D Check This Block
The heater shall be Underwriters Laboratories Inc. Listed and Canadian Standards Association Certified for constant use in Class I, Groups B, C and D, Division 1 or 2 hazardous locations, and National Electric Code minimum gas ignition temperature identification number
 T2A, 280°C (536°F) or T3A, 180°C (356°F).

2 Construction

- 2.1 The back panel shall be designed to be easily mounted to the wall using keyhole slots.
- 2.2 The back panel shall be fabricated from 16 gauge steel, 8-15/16" deep by 20" high protected by zinc chromate primer and coated with corrosion resistant polyester powder paint.
- 2.3 The back panel shall include perforations and a baffle to direct outside air between the panel and the mounting surface.
- 2.4 The front cabinet shall be easily removable by unthreading 4 bolts from threaded inserts.
- 2.5 The front cabinet shall be fabricated from 16 gauge steel, 8-15/16" deep by 20" high, protected by a zinc chromate primer and coated with corrosion resistant polyester powder paint.
- 2.6 The front cabinet shall be sloped to prevent objects from being placed on top causing restricted air flow.

3 Elements

- 3.1 The elements shall be constructed of heavy duty resistance wire (80% Nickel, 20% Chromium) insulated by magnesium oxide refractory, which has been highly compacted to transmit heat and act as an electrical insulator.
- 3.2 The elements to be contained in a metal tube, which is then swaged to an O.D. of 1.25".
- 3.3 The element assembly is inserted into a copper tube with 3" x 3.25" aluminum fins spaced at 48 fins per linear foot.
- 3.4 The finned assembly is to be mounted to the rear panel by powder coated brackets.

4 Control (Optional)

- 4.1 The CVEP shall include the following built-in control features:
 operating temperature control
 magnetic contactor
 control transformer with 120V 24V secondary
 Group C and D
 Groups B, C and D
- 4.2 The control components shall be factory installed, wired and tested.

5 Terminal Box (For units without transformer or contactor options)

The terminal box shall be constructed of malleable iron, to include a grounding lug and to be UL listed for Class I Hazardous locations (as indicated in 1. General Specifications above).

Sample Specifications

Temperature Rating T3A 356°F (180°C) Group B, C and D

Ordering Information

kW	BTU	Volts	Phase	Amps	Model No.	Status*	PCN	Wt. (lbs.)
1.6	5,500	208	1	7.7	CVEP-16-81-00-00	NS	088336	58
		208	3	4.5	CVEP-16-83-00-00	NS	086844	
		240	1	6.7	CVEP-16-21-00-00	NS	086852	
		240	3	3.8	CVEP-16-23-00-00	NS	086860	
		277	1	5.8	CVEP-16-71-00-00	NS	086879	
		480	1	3.3	CVEP-16-41-00-00	NS	086887	
3.2	11,000	480	3	1.9	CVEP-16-43-00-00	NS	086895	94
		575	1	2.8	CVEP-16-61-00-00	NS	086908	
		208	1	15.4	CVEP-32-81-00-00	NS	086961	
		208	3	9.0	CVEP-32-83-00-00	NS	086924	
		240	1	13.3	CVEP-32-21-00-00	NS	086932	
		240	3	7.7	CVEP-32-23-00-00	NS	086940	
4.9	13,600	277	1	11.6	CVEP-32-71-00-00	NNS	086959	112
		480	1	6.7	CVEP-32-41-00-00	NS	086967	
		480	3	3.8	CVEP-32-43-00-00	NS	086975	
		575	1	5.6	CVEP-32-61-00-00	NS	086983	
		208	1	19.2	CVEP-40-81-00-00	NS	086991	
		208	3	11.1	CVEP-40-83-00-00	NS	087003	
4.9	13,600	240	1	16.7	CVEP-40-21-00-00	NS	087011	112
		240	3	9.6	CVEP-40-23-00-00	NS	087020	
		277	1	14.4	CVEP-40-71-00-00	NS	087038	
		480	1	8.3	CVEP-40-41-00-00	NS	087046	
		480	3	4.8	CVEP-40-43-00-00	NS	087054	
		575	1	7.0	CVEP-40-61-00-00	NS	087062	

Temperature Rating T2A 536°F (280°C) Group B, C and D

Ordering Information

kW	BTU	Volts	Phase	Amps	Model No.	Status*	PCN	Wt. (lbs.)
1.8	6,156	120	1	15.0	CVEP-18-11-00-00	NS	028759	46
		208	1	8.7	CVEP-18-81-00-00	NS	028767	
		208	3	5.0	CVEP-18-83-00-00	NS	028775	
		240	1	7.5	CVEP-18-21-00-00	NS	028783	
		240	3	4.4	CVEP-18-23-00-00	NS	028791	
		277	1	6.5	CVEP-18-71-00-00	NS	028804	
3.6	12,300	480	1	3.75	CVEP-18-41-00-00	NS	028812	58
		480	3	2.2	CVEP-18-43-00-00	NS	028820	
		208	1	17.3	CVEP-36-81-00-00	S	087070	
		208	3	10.0	CVEP-36-83-00-00	NS	087089	
		240	1	15.0	CVEP-36-21-00-00	S	087097	
		240	3	8.7	CVEP-36-23-00-00	NS	087100	
7.6	24,000	277	1	13.0	CVEP-36-71-00-00	S	087118	94
		480	1	7.5	CVEP-36-41-00-00	S	087126	
		480	3	4.3	CVEP-36-43-00-00	NS	087134	
		575	1	6.3	CVEP-36-61-00-00	NS	087142	
		208	1	36.5	CVEP-76-81-00-00	NS	085913	
		208	3	21.1	CVEP-76-83-00-00	S	085921	
9.0	30,700	240	1	31.7	CVEP-76-21-00-00	NS	085930	112
		240	3	18.3	CVEP-76-23-00-00	S	085948	
		277	1	27.4	CVEP-76-71-00-00	NS	085956	
		480	1	15.8	CVEP-76-41-00-00	NS	085964	
		480	3	9.2	CVEP-76-43-00-00	S	085972	
		575	1	13.2	CVEP-76-61-00-00	NS	085980	
9.0	30,700	208	1	43.3	CVEP-90-81-00-00	NS	087230	112
		208	3	25.0	CVEP-90-83-00-00	NS	087249	
		240	1	37.5	CVEP-90-21-00-00	NS	087257	
		240	3	21.7	CVEP-90-23-00-00	NS	087265	
		277	1	32.5	CVEP-90-71-00-00	NS	087273	
		480	1	18.8	CVEP-90-41-00-00	NS	087281	
9.0	30,700	480	3	10.8	CVEP-90-43-00-00	NS	087290	112
		575	1	15.7	CVEP-90-61-00-00	NS	087302	

*Status: NS = Non-stock S = Stock

Other sizes and configurations are available. Contact your local Chromalox Sales Office.

To Order: Specify Quantity, Model Number, PCN, Volts and kW.

Dimensions (In.)

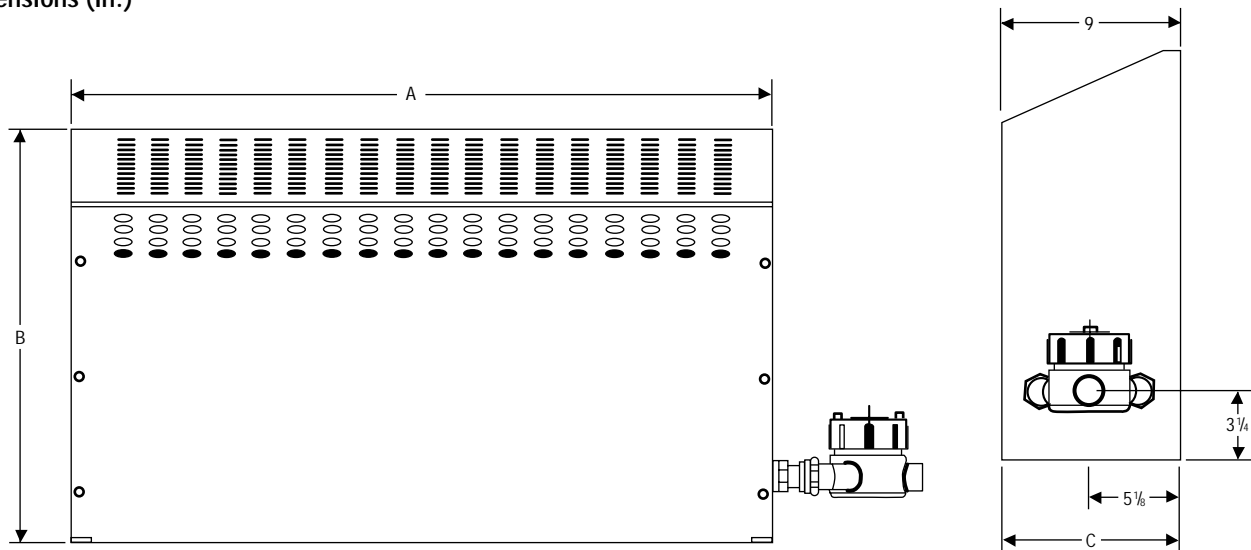

Dimensions (In.)

kW	A	B	C
1.6, 1.8 and 3.6	36	20	9
3.2 and 7.6	58	20	9
4.0 and 9.0	72	20	9

Power & Temperature Control Options

Power Control Combination	Thermostat Option	Figure Number
00	00	1
00	40	4
00	42	2
30 - 35	00	5
30 - 35	40	4
30 - 35	42	3

Dimensions (In.)

Figure 1

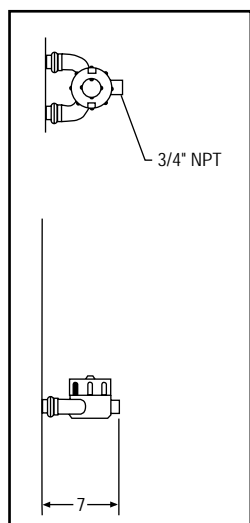

Figure 2

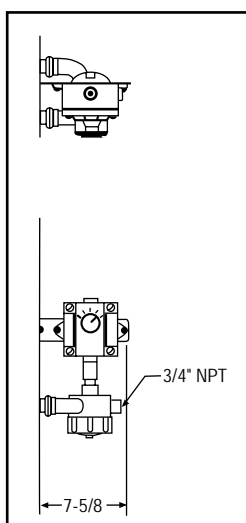

Figure 3

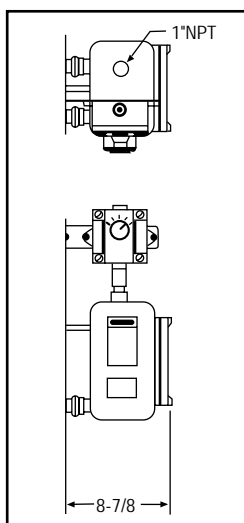

Figure 4

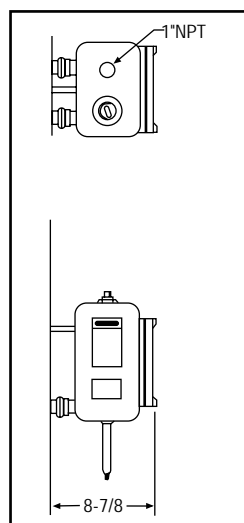
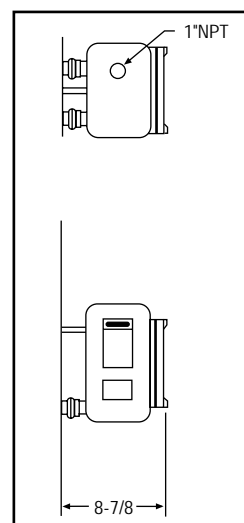

Figure 5



MANUFACTURER MODEL NUMBER BREAKDOWN (located on unit nameplate)

MODEL

Explosion Proof Convection Heater						
CVEP	Code	kW	ID Number	°F	°C	(BTU)
	16	1.6	T3A	356	180	5,500
	18	1.8	T2A	536	280	6,150
	32	3.2	T3A	356	180	11,000
	36	3.6	T2A	536	280	12,300
	40	4.0	T3A	356	180	13,600
	45	4.5	T2A	536	280	15,350
	76	7.6	T2A	536	280	25,930
	90	9.0	T2A	536	280	30,700
	Code	Voltage	Maximum kW Allowable			
	1	120	1.8			
	2	240	9.0			
	3	380	9.0			
	4	480	9.0			
	5	415	9.0			
	6	575	9.0			
	7	277	9.0			
	8	208	9.0			
	9	600	9.0			
	Code	Phase				
	1	1Ø				
	3	3Ø (Not available in 120, 277V)				
	Code	Control Combination				
		Contactors	Transformer			
		Coil	Secondary			
	00	None	None			
	30	24 Volt	24 Volt			
	31	24 Volt	None			
	32	120 Volt	120 Volt			
	33	120 Volt	None			
	34	208/240 Volt	None			
	35	277 Volt	None			
	Code	Temperature Control				
	00	None				
	40	Thermostat 40 - 90°F Group B, C & D				
	42	Thermostat Group C & D 50 - 90°F				
CVEP	36	2	1	30	42	