

Chromalox®

PRECISION HEAT AND CONTROL

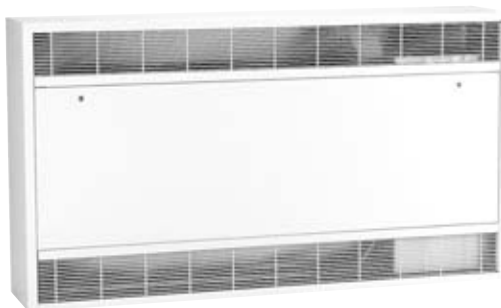

FILE #E7061



SUBMITTAL SHEET

CCH Series Cabinet Console Heater

Capacities

- 2KW, 3KW, 4KW, 5KW, 6KW, 8KW, 10KW, 12KW, 15KW & 18KW
- Single or Three Phase Voltage 208V, 240V & 480V
- Cabinet Lengths Inches 32", 45" and 65"

JOB NAME: _____

LOCATION: _____

ARCHITECT: _____

ENGINEER: _____

CONTRACTOR: _____

SUBMITTED BY: _____

DATE: _____

QTY.	CATALOG NUMBER	TAG	CFM	HEATER			AMPS	BUILT-IN-CONTROLS
				KW	VOLTS	Ø		

ACCESSORIES
AND
CONTROLS

QTY.	CATALOG NO.	TAG	DESCRIPTION

CCH SERIES

Specification Guide

Cat. No.	Watts	BTU	Voltage Option	CFM	Width (in.)	Weight (lbs.)
CCH3D02	2000	6840	A,B,C,D,F,G,J	250/200	32.0	110.0
CCH3D03	3000	10260	A,B,C,D,F,G,J	250/200	32.0	110.0
CCH3D04	4000	13700	A,B,C,D,F,G,J	250/200	32.0	110.0
CCH3D05	5000	17100	A,B,C,D,F,G,J	250/200	32.0	110.0
CCH3D06	6000	20500	A,B,C,D,F,G,J	250/200	32.0	110.0
CCH4D04	4000	13700	A,B,C,D,F,G,J	500/400	45.0	145.0
CCH4D06	6000	20500	A,B,C,D,F,G,J	500/400	45.0	145.0
CCH4D08	8000	27300	A,B,C,D,F,G,J	500/400	45.0	145.0
CCH4D10	10000	34120	A,B,C,D,F,G,J	500/400	45.0	145.0
CCH4D12	12000	41000	A,B,C,D,F,G,J	500/400	45.0	145.0
CCH6D15	15000	51180	D,F,J	750/600	65.0	240.0
CCH6D18	18000	61416	D,F,J	750/600	65.0	240.0

Sample Specifications Logic

Model Option	Voltage Option	Control Option	Color Option
4000W	208/1 Phase	Built-in Thermostat Hi/Low Switches & On/Off Switch	White
CH4D04	- A	- 3	- W

Control Options (Factory Installed)

Code	Description
3	Built-in single pole thermostat control High/low control switch for heat/fan, on/off control switch
T	Build-in low voltage relay kit for remote 24V thermostat (not included) High/low control switch for heat/fan
R	Relay for 208/240V wall thermostat High/low control switch for heat/fan
C	Duct transition collar for connection to ducting
S	Disconnect switch for positive power interruption
X	High speed motor ceiling mount applications

Accessories (Field Installed)

Cat. No.	Description
TF32	Trim frame for recess mounting of 32" cabinets
TF45	Trim frame for recess mounting of 45" cabinets
TF65	Trim frame for recess mounting of 65" cabinets
PWF45	Permanent washable filter for 45" cabinets
PWF65	Permanent washable filter for 65" cabinets

Trim frames are almond - to order white, add "W" to end of Cat. No.

Voltage Selection

Code	Voltage/Phase
A	208/1
C	277/1
D	208/3
E	240/3
F	480/3
G	480/1
J	600/3

Color Option

Code	Color
I	Ivory
W	White

Dimensions

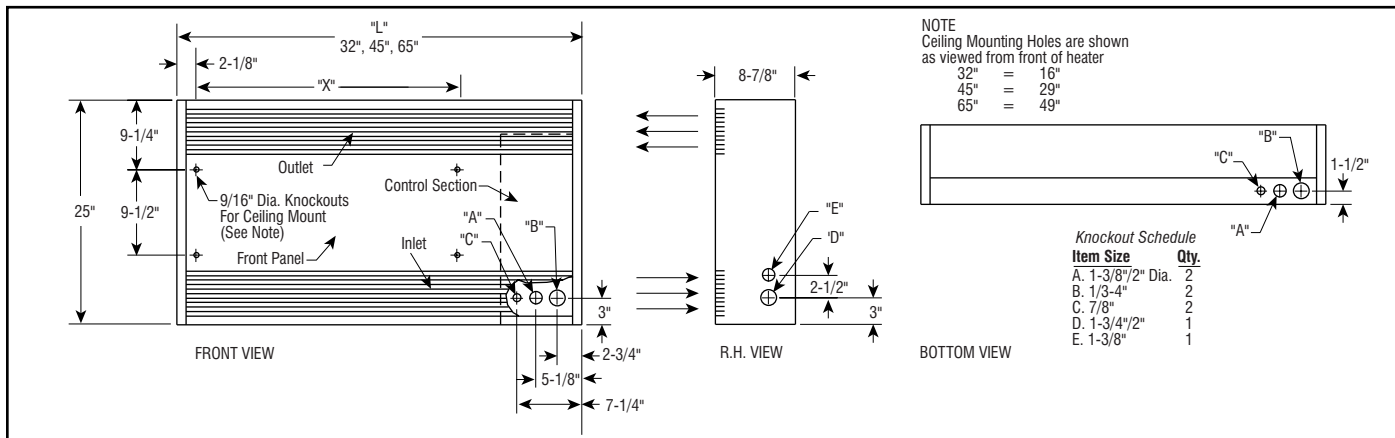

ARCHITECTURAL ENGINEER SUGGESTED SPECIFICATIONS

CCH Series

Construction

Cabinet console heaters shall be 25" high; 8-7/8" deep. All panels are to be fabricated with 16 gauge steel. The cabinet grills shall be field adjustable and shipped standard as front inlet front outlet. Architectural style bar grills must be able to be relocated in the field for top/bottom inlet/outlet arrangements. Units must be designed to operate partially or fully recessed or ceiling mounted and have trim frames available. An optional duct transition collar shall be available for connecting to ducting. Optional permanent type air filters shall be available.

Color

Color shall be almond.

Finish

Painted finish shall be hybrid polyester epoxy powder coat process.

Heating Element

Heating element to be heavy duty, with a steel sheath, enclosing a nickel chromium element imbedded in compacted mineral insulation. Steel fins shall be continuous spiraled and permanently bonded to the sheath. The fins shall provide maximum heating surface and maximum heat transfer at a safe temperature level.

Controls

The heater shall be available with a choice of control combinations to provide flexibility of operation in various applications. All units must include a two-position rotary switch for High & Low heat and blower output and a time delay relay to remove residual heat before shut-off. This heater shall be available with any of the following, optional, controls. Built-in single pole thermostat (45 to 90°F) and a 3 button push button (OFF, HEAT and FAN) switch, built-in 24 volt relay kit for remote room thermostat, provision for remote wire control or a disconnect switch for positive power interruption.

Fan and Motor

All motors are to be resilient mounted and have built-in automatic reset thermal overload protection. Motors are to have plug-in electrical connections for ease of service. Motors and blowers are to be mounted as a single assembly with direct-drive connection on a rigid heavy gauge frame to prevent vibration. A blow-through design shall be used to assure quiet operation and maximum cooling for the blower motor.

Motor volts same as heater for 208, 240 and 277 volt units. 480 and 600 volt units use 240V motors.

Thermal Protection

A linear high temperature thermal cutout shall be provided for the full length of the heating element.