

Chromalox®

PRECISION HEAT AND CONTROL



FILE #E171404



CAF-12



CCAS-12

SUBMITTAL SHEET CAF-12 & CCAS-12 Architectural Convection Heaters

Capacities

750 w/ft. - 1500W, 3000W, 4500W, & 6000W

562 w/ft. - 1125W, 1687W, 2250W, 3375W & 4500W

Single Phase Voltage

208V, 240V & 277V

Three Phase Voltage

208V & 480V

Heater Lengths Inches

24.3", 48.3", 72.3", 84.3" & 96.3"

JOB NAME: _____

LOCATION: _____

ARCHITECT: _____

ENGINEER: _____

CONTRACTOR: _____

SUBMITTED BY: _____

DATE: _____

QTY.	CATALOG NUMBER	TAG	HEATER			AMPS	BUILT-IN-CONTROLS
			KW	VOLTS	Ø		

ACCESSORIES
AND
CONTROLS

QTY.	CATALOG NO.	TAG	DESCRIPTION

CAF12 SERIES

Architectural Convection Heater

Specification Guide

Cat. No.	Watts	BTU	Available Voltages		Length 3 Phase	Weight (in.)	Weight (lbs.)
			1 Phase	3 Phase			
Standard Density 750 w/ft.							
CAF12F215	1500	5118	208, 240, 277	208, 480	24.3	50.9	
CAF12F430	3000	10236	208, 240, 277	208, 480	48.3	77.7	
CAF12F645	4500	15354	208, 240, 277	208, 480	72.3	104.5	
CAF12F860	6000	20472	208, 240, 277	208, 480	96.3	131.3	
Low Density 562 w/ft.							
CAF12F211	1125	3838	208, 240, 277	208	24.3	50.9	
CAF12F316	1687	5756	208, 240, 277	208, 480	36.3	64.3	
CAF12F422	2250	7677	208, 240, 277	208, 480	48.3	77.7	
CAF12F633	3375	11515	208, 240, 277	208, 480	72.3	104.5	
CAF12F845	4500	15354	208, 240, 277	208, 480	96.3	131.3	

Low watt density ranges available — consult factory.

Control Options (Factory Installed)

Code	Description
A9	Built-in DP tamperproof hydraulic thermostat 208 - 277V
A3	Built-in 3P tamperproof hydraulic thermostat for 3 phase 208 - 480V
A4	Built-in 24V low voltage relay for 1P voltages 208-277V
A5	Built-in 24V low voltage relay and transformer for 1P voltages 208 - 277V
A6	Built-in 24V contactor less transformer for 3P voltages 208 - 480V
A7	Built-in 24V contactor and transformer for 3P voltages 208 - 480V
A8	Built-in disconnect switch, rated 277V20A
B9	Built-in DP tamperproof thermostat and disconnect
B3	Built-in 3P tamperproof thermostat and disconnect

Sample Specifications Logic

CAF12	B	2	15	21	02	A9	S
Series	*Bottom Inlet	2' Length	1500W	208V/1P	White	Built-in DP tamperproof hydraulic thermostat	Finished Back

*Note: F = Front inlet
B = Bottom inlet

1. Specify desired voltage, finish and control option from tables.
2. For bottom inlet version replace "F" in catalog number with "B".
3. End caps are included with heaters.
4. Consult factory for custom finish requirements.

Accessories (Field Installed)

Cat. No.	Description
ALF121C90	Inside 90 degree corner
ALF120C90	Outside 90 degree corner
Filler Sections	Consult factory for available sizes
Specify finish code when ordering accessories.	

Finish Selection

Painted	Anodized
68 Almond	07 Bronze
02 White	10 Clear

Voltage Selection

Code	Voltage/Phase
21	208/1
23	208/1
31	240/1
41	277/1
73	480/3

Cabinet Features

Add "S" or "W" to end of cat. no. for:
W — Pedestal and finished back
S — Finished painted back

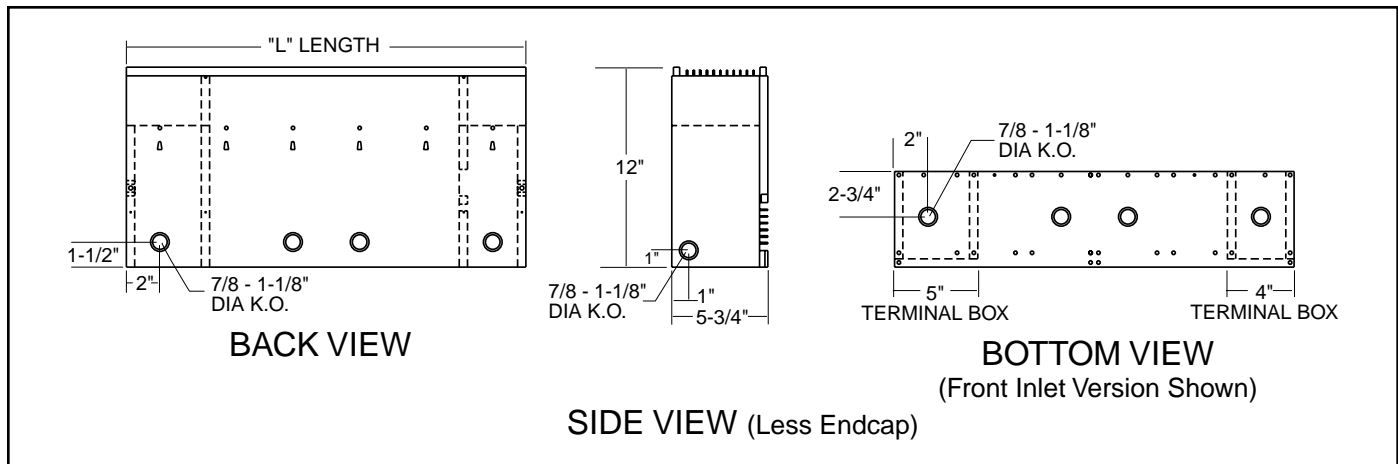

ARCHITECTURAL ENGINEER SUGGESTED SPECIFICATIONS

CAF-12 Series

Construction

Heaters shall be 12" high, 5 3/4" deep, with the top and front constructed of extruded aluminum equivalent in strength to 14 gauge steel. The inlet grill shall be interchangeable, front or bottom, and outlet grill located on the heater top. Cabinet back and bottom to be fabricated from satin coat steel with multiple knock outs for convenient power connection. Endcaps to be field removable for continuous heater installation.

Color

Color shall be _____ (Standard White or Almond. Clear and Bronze 40 available).

Finish

Painted finish shall be hybrid polyester epoxy powder coat process. Clear and Bronze 40 are anodized aluminum finishes.

Heating Element

Heating element to be heavy duty, corrosion resistant, stainless steel sheath, enclosing a nickel chromium element imbedded in compacted mineral insulation. Aluminum fins are to be positively staked to the surface and provide superior heat transfer. Element is to be located in a floating suspension system to eliminate expansion noise.

Controls

(Optional) Heaters to include built-in tamper proof thermostat mounted in the _____ (left or right) terminal box. Built-in low voltage control to be located in the right hand terminal box. Built in disconnect switch is to be located in the right hand terminal box. Power connection to be made at either the right or left end of the heater. A continuous wireway to be standard to facilitate continuous installation of multiple heaters.

Thermal Protection

A linear high temperature thermal cutout shall be provided for the full length of the heating element.

CCAS12 SERIES

Architectural Slope Top Heater

Specification Guide

Cat. No.	Watts	BTU	Available Voltages		Length 3 Phase	Weight (in.)	(lbs.)
			1 Phase	3 Phase			
Standard Density 750 w/ft.							
CCAS12F215	1500	5118	208, 240, 277		208, 480	24.3	50.9
CCAS12F430	3000	10236	208, 240, 277		208, 480	48.3	77.7
CCAS12F645	4500	15354	208, 240, 277		208, 480	72.3	104.5
CCAS12F860	6000	20472	208, 240, 277		208, 480	96.3	131.3
Low Density 562 w/ft.							
CCAS12F211	1125	3838	208, 240, 277		208	24.3	50.9
CCAS12F316	1687	5756	208, 240, 277		208, 480	36.3	64.3
CCAS12F422	2250	7677	208, 240, 277		208, 480	48.3	77.7
CCAS12F633	3375	11515	208, 240, 277		208, 480	72.3	104.3
CCAS12F845	4500	15354	208, 240, 277		208, 480	96.3	131.3

Low watt density ranges available — consult factory.

Sample Specifications Logic

CCAS12	B	2	15	21	02	A9	S
Series	*Bottom Inlet	2" Length	1500W	208V/1P	White	Built-in SP tamperproof hydraulic thermostat	Finished painted back

*Note: F = Front inlet
B = Bottom inlet

1. Specify desired voltage, finish and control option from tables.
2. For bottom inlet version replace "F" in catalog number with "B".
3. End caps are included with heaters.
4. Consult factory for custom finish requirements.

Control Options (Factory Installed)

Code	Description
A9	Built-in DP tamperproof hydraulic thermostat 208 - 277V
A3	Built-in 3P tamperproof hydraulic thermostat for 3 phase 208 - 480V
A4	Built-in 24V low voltage relay for 1P voltages 208-277V
A5	Built-in 24V low voltage relay and transformer for 1P voltages 208 - 277V
A6	Built-in 24V contactor less transformer for 3P voltages 208 - 480V
A7	Built-in 24V contactor and transformer for 3P voltages 208 - 480V
A8	Built-in disconnect switch, rated 277V20A
B9	Built-in DP tamperproof thermostat and disconnect
B3	Built-in 3P tamperproof thermostat and disconnect

Accessories (Field Installed)

Cat. No.	Description
ALS121C90	Inside 90 degree corner
ALS120C90	Outside 90 degree corner
Filler Sections	Consult factory for available sizes

Specify finish code when ordering accessories.

Finish Selection

Painted	Anodized
68 Almond	07 Bronze
02 White	10 Clear

Cabinet Features

Add "S" or "W" to end of cat. no. for:
W — Pedestal and finished back
S — Finished painted back

Voltage Selection

Code	Voltage/Phase
21	208/1
23	208/1
31	240/1
41	277/1
73	480/3

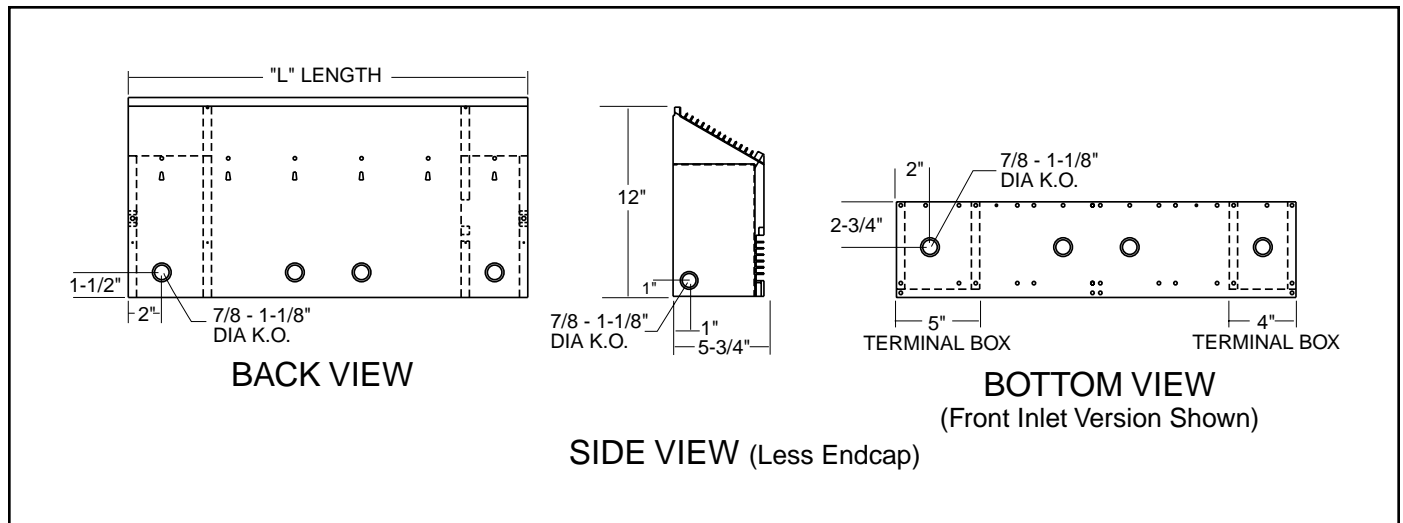

ARCHITECTURAL ENGINEER SUGGESTED SPECIFICATIONS

CCAS-12 Series

Construction

Heaters shall be low profile 12" high, 5/8" deep, with the top and front constructed of extruded aluminum equivalent in strength to 14 gauge steel. The inlet grill shall be interchangeable, front or bottom, and outlet grill located on the heater top. Cabinet back and bottom to be fabricated from satin coat steel with multiple knock outs for convenient power connection. Endcaps to be field removable for continuous heater installation.

Color

Color shall be _____ (Standard White or Almond. Clear and Bronze 40 available).

Finish

Painted finish shall be hybrid polyester epoxy powder coat process. Clear and Bronze 40 are anodized aluminum finishes.

Heating Element

Heating element to be heavy duty, corrosion resistant, stainless steel sheath, enclosing a nickel chromium element imbedded in compacted mineral insulation. Aluminum fins are to be positively staked to the surface and provide superior heat transfer. Element is to be located in a floating suspension system to eliminate expansion noise.

Controls

(Optional) Heaters to include built-in tamper proof thermostat mounted in the _____ (left or right) terminal box. Built-in low voltage control to be located in the right hand terminal box. Built in disconnect switch is to be located in the right hand terminal box. Power connection to be made at either the right or left end of the heater. A continuous wireway to be standard to facilitate continuous installation of multiple heaters.

Thermal Protection

A linear high temperature thermal cutout shall be provided for the full length of the heating element.

