

Chromalox®

Installation, Operation

and

RENEWAL PARTS IDENTIFICATION

SERVICE REFERENCE

DIVISION 4	SECTION cas
SALES REFERENCE (Supersedes PQ435)	PQ435-1
161-562795-001	
DATE	JUNE, 1994

Type CAS-20CM Electric Steam Boiler (Standard Trim is 100 PSI — 0-90 PSI Operating Pressure Range)



Boiler Serial No. _____	Power Circuit Voltage _____
Model No. _____	Control Circuit Voltage _____
National Board No. _____	Amps _____ Phase _____ Cy _____

IMPORTANT – This data file contains the National Board Registration Certificate approving your boiler. It must be kept near the boiler at all times.

Model	Electric Capacity	BHP Rating	Voltage	Phase	Amperes Drawn	Contactor
CAS-20CM	20 kW	2.0	208	1	96	50A, 4 Pole
	16/20 kW	1.6/2.0	208/230	3	45/51	60A, 3 Pole
	20 kW	2.0	240	1	84	50A, 4 Pole
	20 kW	2.0	346	3	34	40A, 3 Pole
	20 kW	2.0	380	1	53	60A, 2 Pole
	20 kW	2.0	480	3	24	30A, 3 Pole

Note: Control circuit 120V

INSTALLATION

WARNING: To avoid electrical shock hazard, boilers must be suitably grounded to earth.

Note: Chromalox boilers are pre-tested before shipment; no internal piping or wiring is necessary. **WARNING:** Substitution of components or modification of wiring without prior consent of components or modification of wiring without prior consent of Wiegand Industrial Division. Emerson Electric Co. voids warranty.

1. Bolt unit securely to level floor or platform.

Note: A minimum distance of 18 inches from wall, other equipment, etc. must be allowed for removal of the elements.

2. Complete all piping to boiler. Connect water line to tagged fitting on the motor and pump assembly if used, or to tagged fitting on water control feeder.

3. When any type of feed other than a pump feed is used, the water supply line pressure must be 10 pounds greater than the boiler operating pressure to assure proper water level in boiler. Lack of water can cause heater failure. Keep feed water line valves open at all times.

4. Connect steam line (with outlet valve) to boiler steam outlet.

5. Open all gauge valves and steam outlet valve; keep drain valve closed.

Note: The safety valve should be provided with a drain line sized no less than the outlet size of the valve and routed per local codes.

6. Floor drain to be provided directly below unit.

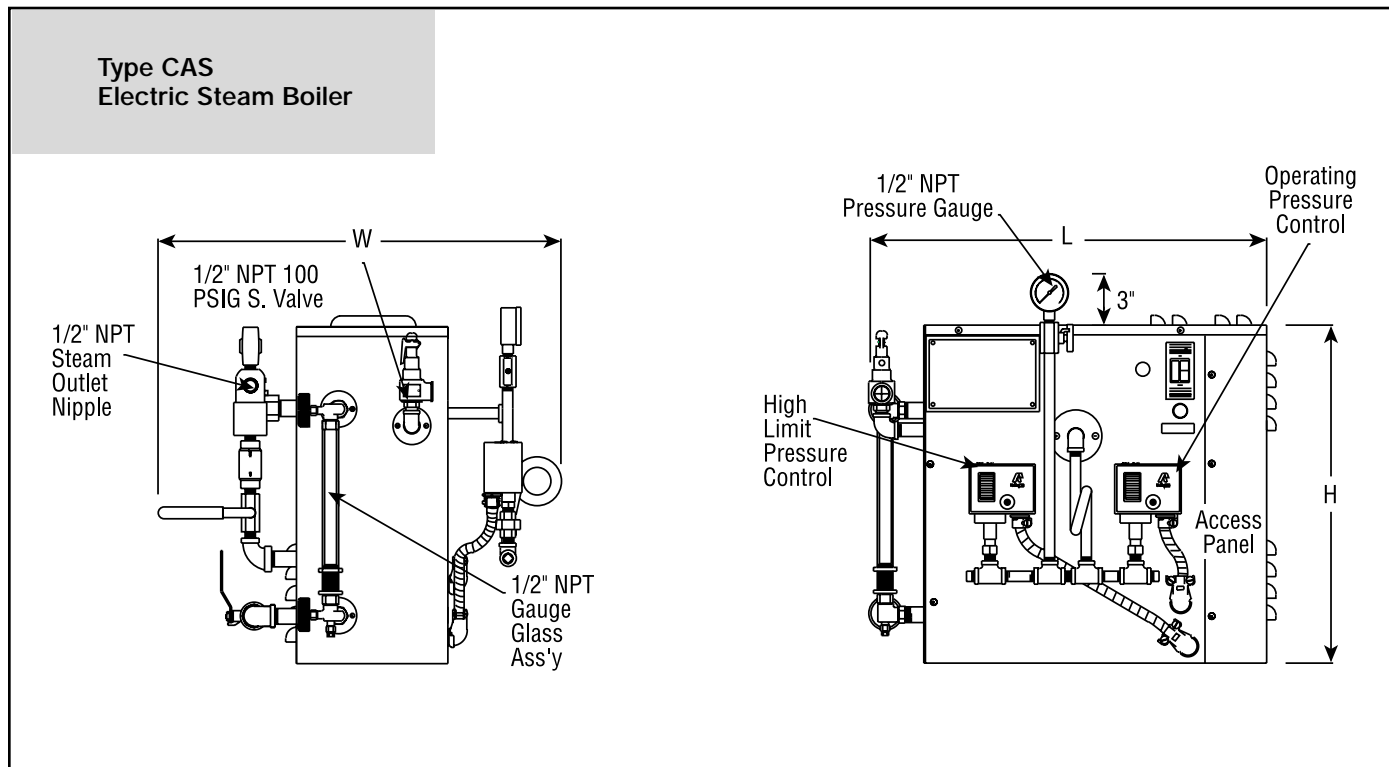

WIRING

WARNING: Hazard of Electrical Shock. Disconnect all power before working on boiler. Boilers must be grounded in accordance with the National Electrical Code (NEC) standards to avoid shock hazard.

WARNING: Use 90°C copper conductors only.

1. Select proper wire gauge and type for supply conductors in accordance with the National Electrical Code and local wiring codes following wiring diagram supplied (See recommendations for disconnect switches and fusing).

Note: Purchaser should use a safety disconnect employing circuit breakers or fuses between the main power source and the boiler. This overcurrent protection should be installed in addition to any other supplementary fuses or circuit breakers provided as an integral part of the boiler.

2. If a separate control circuit is used, the control circuit should be connected to the control terminal block and the circuit protected by overcurrent devices in accordance with the National Electrical Code.

3. Chromalox boilers are solid state devices. Since boilers are connected to water lines, these devices are susceptible to voltage surges and lightning damage. Industrial type lightning pro-

tectors should be installed per manufacturer's recommendations at your service entrance.

4. Be sure that all electrical connections are sufficiently tightened. Loose connections will cause overheating and damage to the electrical wiring.

5. Special instructions for customers supplying their own condensate or pump system.

A. Check the voltage of the motor before making the wiring connection. The motor should always match the voltage of the control circuit. Standard control circuit voltage is 120 volts \pm 10 volts.

B. Internal water feed relay is rated at a maximum of $\frac{1}{3}$ H.P., 120 volts. Motors rated greater than $\frac{1}{3}$ H.P., or other than 120V, single phase, require the use of a suitable motor starter.

6. After all service connections are made, open feed water supply valve and energize the boiler. The feed water solenoid will open, fill the boiler to the proper water level and automatically shut off. The feed solenoid will continuously cycle on and off as the boiler requires water. If, for any reason, the water drops below the minimum safe operating level, the boiler's electrical circuits, except the feed solenoid will be de-energized automatically. Upon refilling to the proper level, the boiler will automatically restart.

SCHEMATIC WIRING DIAGRAM

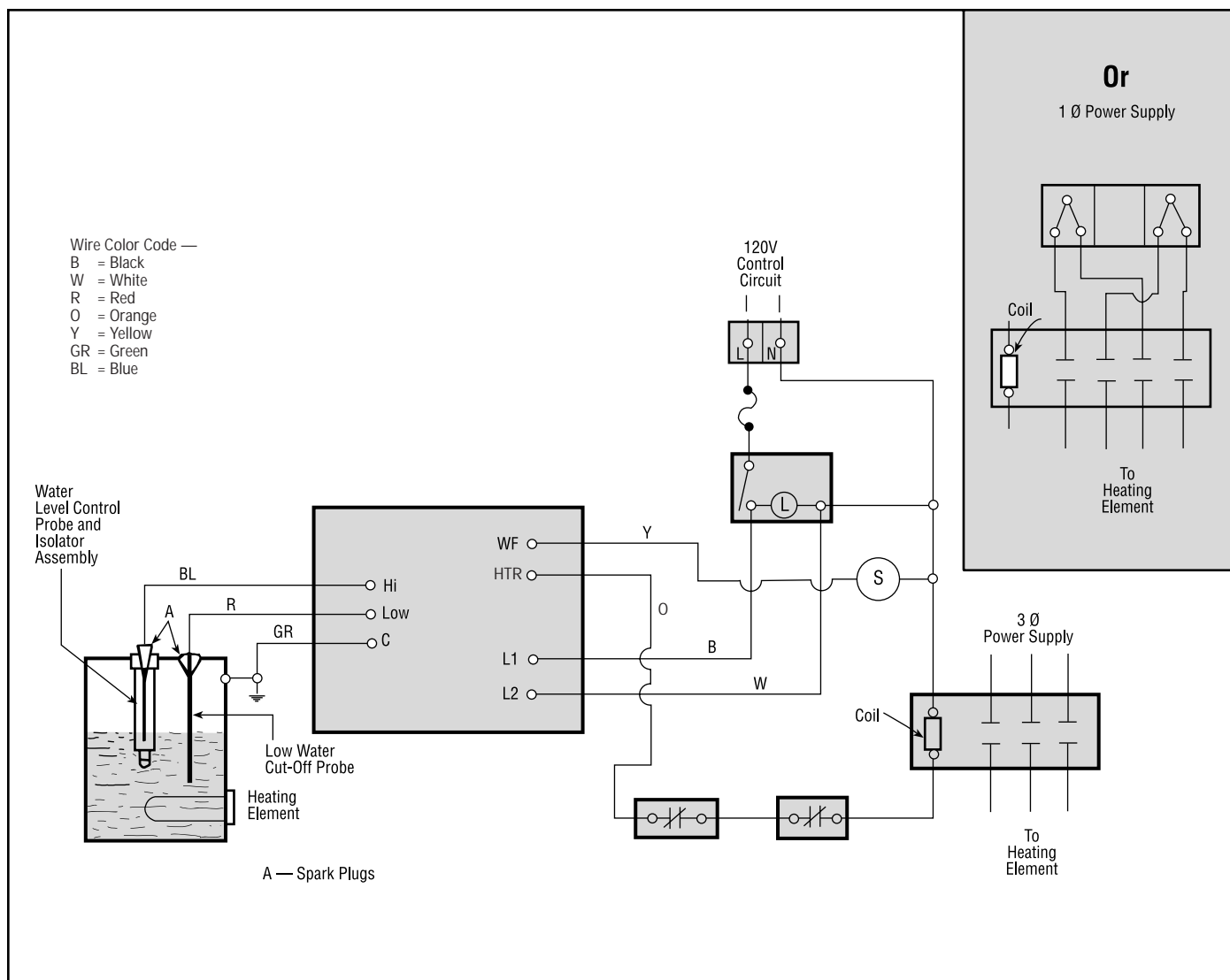

OPERATION

SOLID STATE FLOATLESS LIQUID LEVEL CONTROL SYSTEM

This boiler is equipped with a solid state, floatless liquid level control which operates by sensing the electrical resistance of water. **Note:** Control will not work with de-ionized or demineralized water. Two probes are provided. The HI probe activates and controls the feed water relay. The LOW probe is a safety back-up probe that turns off the power to the element in the event of low water. A 12 volt potential is established between each probe and ground. The presence or absence of water generates a small signal that is amplified and fed to a SCR. The SCR, in turn, activates a relay, depending on the function and the water level.

ADJUSTING PRESSURE CONTROLS

Chromalox boilers are supplied with operating and high limit pressure controls. One is used for controlling the operating pressure of the boiler while the other is used as a high limit control.

MANUAL BLOWDOWN INSTRUCTIONS

Blowdown is an essential part of boiler operation. It is the best preventive maintenance you can give your boiler and will add years of life to the unit. Make sure a blowdown schedule is established and followed regularly.

Blowdown will remove accumulated hard water scale and dislodge scale from water heating surface thereby insuring efficient heating. In extremely hard water areas blowdown is necessary

once a day. In soft water areas, once each week. If water is known to be corrosive, consult water treating specialists to recommend water treatment needed to insure corrosion free boiler operation. If there is a particular problem which applies to your own local water condition other than mineral content, take this into consideration in determining what schedule is to be followed.

1. At the end of the working day turn switch to the OFF position and close water supply valve. De-energize wall mounted safety switch (main power supply).
2. If blowing down into a receptacle, cover receptacle to prevent splash of scalding water.
3. It is preferable to connect the blowdown valve directly into a drainage system. If this is done, the boiler can be discharged at operating pressure. However, check local codes and suitability of drainage system before connecting.
4. When blowdown is complete and boiler is drained (a) close the blowdown valve; (b) open water supply valve; (c) put boiler switch in the ON position; and, (d) close wall mounted safety switch.
5. When refilling is complete, turn off the boiler switch unless further operation is desired.

The use of chemical boiler cleaning compounds in these boilers voids all warranties unless approved by Wiegand Industrial Division, Emerson Electric Co.

MAINTENANCE

WARNING: *Hazard of Electric Shock. Disconnect all power before working on boiler.*

1. A monthly inspection should be made to ensure that all electrical connections are tight.
2. When steam or water leaks are observed, fittings should be tightened immediately.
3. Every four months, the Solid State Liquid Control probes should be checked for deposits and cleaned if necessary. Remove deposits from probe and teflon sleeve. This is accomplished by removing the inspection plate and with the use of a standard spark plug wrench, removing the probes. Care should be taken during the removal and reinstallation of the probes so the porcelain insulator is not damaged.

The feed water probe is mounted in a surge isolator tube. This isolator tube should be removed and cleaned at the same time as the probes.

Note: Make sure that probe does not touch the insulator tube, as grounding will occur. This will cause boiler to run dry.

4. At the same time, remove the heating element and inspect for scale formation. If scale has begun to form, clean element and also flush boiler.

TROUBLE SHOOTING HINTS

1. Boiler does not energize when main switch is turned on (nothing happens).
 - A. Check to see if main power is turned on.
 - B. Check to see if control circuit voltage is turned on. (ON-OFF switch has a pilot light)
 - C. Check power and control circuit fuses or breakers.
 - D. Check control circuit fuse on boiler.
 - E. Check all electrical connection for tightness.
2. Boiler power control circuit pilot light is on. Boiler will not fill or heat.
 - A. No water in boiler. Check sight glass, it should be $\frac{1}{8}$ to $\frac{1}{2}$ full. Check water feed lines, valves, pumps, strainer, etc. for proper operation.
 - B. Solid state water feed probe inoperative. Check solid state liquid controls probes. Water feed solenoid should activate 10 seconds after control circuit is turned on. Clean probe and isolator tube as required. Make sure probe is straight and does not touch wall.
 - C. Water feed relay bad – replace plug-in relay.
 - D. Solenoid valve bad — replace solenoid valve.
3. Boiler has power and water in sight glass. Boiler will not heat.
 - A. Bad heating contactor. Check for open coil or frozen contacts.
 - B. Bad relay on control Board. Replace control board.
 - C. Burned out element. Replace heating element.
 - D. Loose power connection. Tighten electrical connections.
4. Boiler floods.
 - A. Check high water probe and isolator tube for deposits.
 - B. Check water feed relay for frozen contacts.
 - C. Check solenoid valve, may be stuck or damaged.
5. Element repeatedly burns out.
 - A. Low water cutoff probe damaged or shorted to ground. Remove and check low probe.
 - B. Boiler not supplied with water. Check water feed lines, valves and circuits. Check water feed probe.
 - C. Control board defective. Check operation of board and component. Replace board if necessary.
6. Control board trouble shooting. Start-up sequence. The two probe board has the following sequence of operation when the boiler is initially energized.
 - A. Turn on control circuit power.
 - B. Approximately 10 second delay before water feed solenoid or pump starts.
 - C. Water rises in boiler and contacts low probe which closes relay contacts, turning on heater.
 - D. Water continues to rise to HI probe. Turns off water feed.

Normal Operation Sequence.

1. Water drops below HI probe. After 10 second delay, water feed energizes refilling boiler.
2. Water reaches HI probe and turns off water feed.
3. Sight glass should be $\frac{1}{3}$ to $\frac{1}{2}$ full. Heater contactor will cycle at operating pressure depending on load. Heater contactor should not chatter on short cycle. In the event of contactor chatter, check for low water condition and check for damaged or shorted probes.

Inconsistent water level causing low water cutoff.

1. Test feed solenoid control circuit by energizing control circuit. Remove cover plate from probes.
2. Check for shorted or failed water feed probes.
3. Check water feed lines, valves and circuits.

INSTRUCTIONS FOR ELEMENT REPLACEMENT

Note: Element failure is usually caused by excessive scale build up or low water operating conditions. Before replacing element, be sure boiler tank is clean and free of scale. Check control board, water feed system and control probes for proper operation.

Failure to perform the above maintenance checks may result in immediate burn-out of new elements.

1. A monthly inspection of the boilers, boiler installation and electrical wiring should be made to insure proper operation. These inspections should include:
 - A. Electrical connections. Look for overheated or discolored power terminals. Check and tighten all terminals that may work loose from expansion and contraction.
 - B. Check for steam or water leaks and tighten all pipe fittings.
 - C. Check safety relief valve.
 - D. Check water feed line, strainers and check valves.
 - E. Blow down boiler and make sure drain lines are clear.

Read completely before starting work.

1. Disconnect boiler from electric power supply at main safety switch or fuse panel. Then turn boiler switch to “off” position.
2. On automatic feed units, close valve on incoming water line. Drain boiler completely of water.
3. Remove wiring compartment end panel to expose heating element.
4. Disconnect wire (electric) leads connecting element to main power system of boiler. Again note wire connections to facilitate re-assembly. Proceed to remove (6) $\frac{5}{16}$ -18 bolts from flange.
5. Thoroughly clean boiler flange of all foreign material. Be certain no part of old gasket remains on boiler flange.
6. Apply “Slic-Tite” Gasket Compound (or equivalent) to both surfaces of new gasket supplied with replacement element. Proceed to install element flange assembly with gasket between boiler flange and element flange. In doing this, be careful to align flange holes; element flange is marked “TOP” so wire connection terminals on top element assembly will be in line with previously disconnected wire leads to facilitate easy connections.
7. When all (6) flange bolts are tight, connect all wires to terminals. Make certain wires are clean and bright to assure good electrical contact and nuts on screws are firmly secured.

Note: Bolts should be tightened to a torque of 22 ft. lbs.
8. Open water valve so water supply can reach boiler feed mechanism.
9. Put main safety switch to “ON” position.
10. Turn boiler switch to “ON” position.
11. As boiler automatically refills, observe the new flange assembly for possible leaks. If water is noticed, the bolts must be retightened. *Before doing this, turn the boiler off at the main fuse safety switch.*
12. As boiler is heated to working pressure, check flange assembly again for leaks.

WARNING: *Avoid use of chemical cleaning compounds. Follow maintenance instructions.*

RENEWAL PARTS IDENTIFICATION

HEATING ELEMENTS	
Description	Part Number
20kW 240V 1PH	155-300121-006
20kW 208V 1-3PH	155-554735-023
16/20kW 208/230V 3PH	155-554735-024
20kW 346V 1-3PH	155-554735-051
20kW 380V 1PH	155-554735-042
20kW 480V 3PH	155-554735-030
Element Gasket	132-146012-001
Element Bolt (6 Req'd.)	345-072565-428

ELECTRICAL COMPONENTS	
Description	Part Number
Rocker Switch with Pilot (ON/OFF)	292-053223-002
Contact 30A, 3 pole	072-047913-020
Contact 40A, 3 pole	072-047913-012
Contact 50A, 4 pole	072-047913-021
Contact 60A, 2 pole	072-047913-026
Contact 60A, 3 pole	072-047913-016
Fuse Holder	129-300029-001
Terminal Block, Control	303-075444-001
Terminal Block, Power (1 PH only)	303-047468-003
Fuse 15A, 250V	128-072576-027

GAUGE GLASS PARTS	
Description	Part Number
Sight Glass	374-121046-021
Sight Glass O-Rings	132-073284-001
Valve Set	344-120970-003
Sight Glass Protector	334-056360-002
Nipple, Conduit 1"	198-300084-004

PRESSURE CONTROLS	
Description	Part Number
Operating Pressure Control Auto Reset	292-300031-001
High Limit Pressure Control – Auto Reset	292-300031-001

VALVES AND GAUGES	
Description	Part Number
Safety Valve 1/2", 100 PSIG	334-300032-004
Check Valve 3/8"	344-118536-005
Drain Valve 1/2"	344-121194-006
Solenoid Valve, 120V, 1/4" NPT	344-121780-012
Strainer 1/4"	351-118664-003
Pressure Gauge, 1/4", 0-160 PSIG	130-118661-001

SOLID STATE LEVEL CONTROL PARTS	
Description	Part Number
Probe Level Control, 5 3/8"	242-300036-010
Probe, Cutoff, 5 7/8"	242-300036-011
Control Board with Relay (2 probe)	323-300033-001
Control Board* (1 probe)	323-300033-011
Control Board* (3 probe)	323-300033-006
Relay for Control Board, Plug-in	072-300047-001
Spark Plug	346-300035-001
Probe Isolator (For Level Control)	332-300009-002

*Used on older models.

WARRANTY AND LIMITATION OF REMEDY AND LIABILITY

Chromalox warrants only that the Products and parts manufactured by Chromalox, when shipped, and the work performed by Chromalox when performed, will meet all applicable specification and other specific product and work requirements (including those of performance), if any, and will be free from defects in material and workmanship under normal conditions of use. All claims for defective or nonconforming (both hereinafter called defective) Products, parts or work under this warranty must be made in writing immediately upon discovery, and in any event, within one (1) year from delivery, provided, however all claims for defective Products and parts must be made in writing no later than eighteen (18) months after shipment by Chromalox. Defective and nonconforming items must be held for Chromalox's inspections and returned to the original f.o.b. point upon request. THE FOREGOING IS EXPRESSLY IN LIEU OF ALL OTHER WARRANTIES WHATSOEVER, EXPRESS, IMPLIED AND STATUTORY, INCLUDING, WITHOUT LIMITATION, THE IMPLIED WARRANTIES OF MERCHANTABILITY AND FITNESS FOR A PARTICULAR PURPOSE.

Notwithstanding the provisions of this WARRANTY AND LIMITATION Clause, it is specifically understood that Products and parts not manufactured and work not performed by Chromalox are warranted only to the extent and in the manner that the same are warranted to Chromalox by Chromalox's vendors, and then only to the extent that Chromalox is reasonably able to enforce such warranty, it being understood Chromalox shall have no obligation to initiate litigation unless Buyer undertakes to pay all cost and expenses therefor, including but not limited to attorney's fees, and indemnifies Chromalox against any liability to Chromalox's

vendors arising out of such litigation.

Upon Buyer's submission of a claim as provided above and its substantiation, Chromalox shall at its option either (i) repair or replace its Products, parts or work at the original f.o.b. point of delivery or (ii) refund an equitable portion of the purchase price.

THE FOREGOING IS CHROMALOX'S ONLY OBLIGATION AND BUYER'S EXCLUSIVE REMEDY FOR BREACH OF WARRANTY, AND IS BUYER'S EXCLUSIVE REMEDY AGAINST CHROMALOX FOR ALL CLAIMS ARISING HEREUNDER OR RELATING HERETO WHETHER SUCH CLAIMS ARE BASED ON BREACH OF CONTRACT, TORT (INCLUDING NEGLIGENCE AND STRICT LIABILITY) OR OTHER THEORIES, BUYER'S FAILURE TO SUBMIT A CLAIM AS PROVIDED ABOVE SHALL SPECIFICALLY WAIVE ALL CLAIMS FOR DAMAGES OR OTHER RELIEF, INCLUDING BUT NOT LIMITED TO CLAIMS BASED ON LATENT DEFECTS. IN NO EVENT SHALL BUYER BE ENTITLED TO INCIDENTAL OR CONSEQUENTIAL DAMAGES AND BUYER SHALL HOLD CHROMALOX HARMLESS THEREFROM. ANY ACTION BY BUYER ARISING HEREUNDER OR RELATING HERETO, WHETHER BASED ON BREACH OF CONTRACT, TORT (INCLUDING NEGLIGENCE AND STRICT LIABILITY) OR OTHER THEORIES, MUST BE COMMENCED WITHIN ONE (1) YEAR AFTER THE DATE OF SHIPMENT OR IT SHALL BE BARRED.

W2008M

Chromalox[®]
PRODUCT SERVICE
2150 N. RULON WHITE BLVD., OGDEN, UT 84404
Phone: 1-800-368-2493

WIEGAND INDUSTRIAL DIVISION
EMERSON ELECTRIC CO.

