

Chromalox®

Installation, Operation and **RENEWAL PARTS IDENTIFICATION**

SERVICE REFERENCE	
DIVISION 4	SECTION CES
SALES REFERENCE (Supersedes PQ444)	PQ444-1
161-562789-002	
DATE	MAY, 1999

Type CES-6 through CES-180 Electric Steam Boiler

Standard Trim is 100 PSI — 0-90 Operating Pressure Range

Boiler Serial Number	Power Circuit Voltage
Model	Control Circuit Voltage
National Board No.	Amps Phase Cy

Important — This data file contains the National Board Registration Certificate for your boiler. It must be kept near the boiler at all times.



Model	Rating (BHP)	Elec Cap. (kW)	Vol. (Gals.)	Output at 212 F (Lbs./Hr.)	3 Phase Voltages*			No./kW of Heating Elements
					Quantity and Rating of Contactors			
					208	240	480†	
Type CES — 0-100 PSIG								
CES-6	.6	6	6	18	30	30	30	1-6
CES-9	.9	9	6	27	30	30	30	1-9
CES-12	1.22	12	6	36.2	40	30	30	1-12
CES-18	1.73	17	6	51.2	50	50	30	1-17
CES-24	2.45	24	14.3	72.3	2-40	2-30	2-30	2-12
CES-30	2.95	29	14.3	87.4	1-40 1-50	1-40 1-30	40	1-12 1-17
CES-36	3.47	34	14.3	102.5	2-50	2-50	50	2-17
CES-48	4.69	46	14.3	138.7	1-40 2-50	1-30 2-50	1-40 1-30	1-12 2-17
CES-60	5.91	58	14.3	174.8	2-50 2-40	2-30 2-50	2-40	2-12 2-17
CES-72	6.93	68	14.3	205	4-50	4-50	2-50	4-17
CES-100	10.40	102	27.8	307	6-50	6-50	3-50	6-17
CES-135	13.9	136	30.5	410	—	8-50	4-50	8-17
CES-160	16.1	157.5	30.5	475	—	7-60	1-30 3-60	7-22.5
CES-180	18.4	180	30.5	543	—	8-60	4-60	8-22.5

* Single phase available up to and including 24 kW capacity.
† All boilers must have separate 120V Control Circuit or Transformer.
Boilers under 40 amps max are not fused.

DIMENSIONS

MODEL CES-6 through CES-18

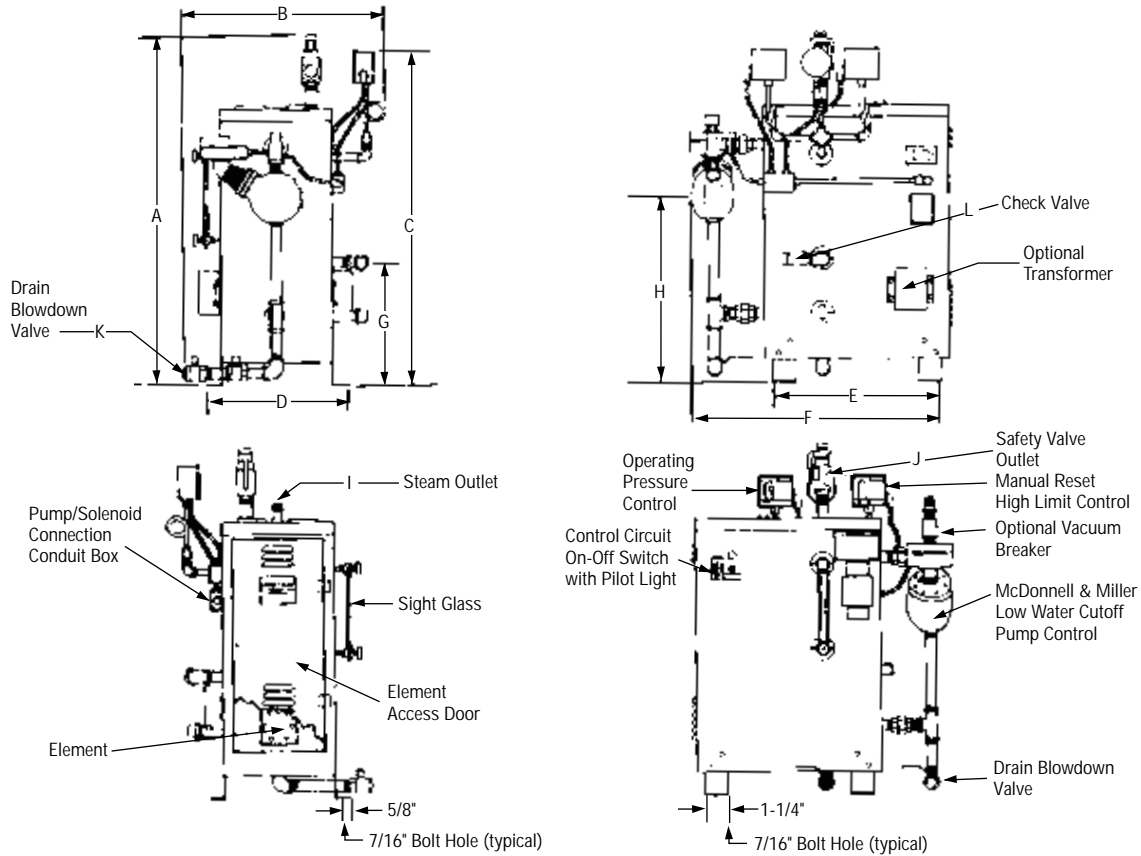

MODEL CES-24 through CES-180

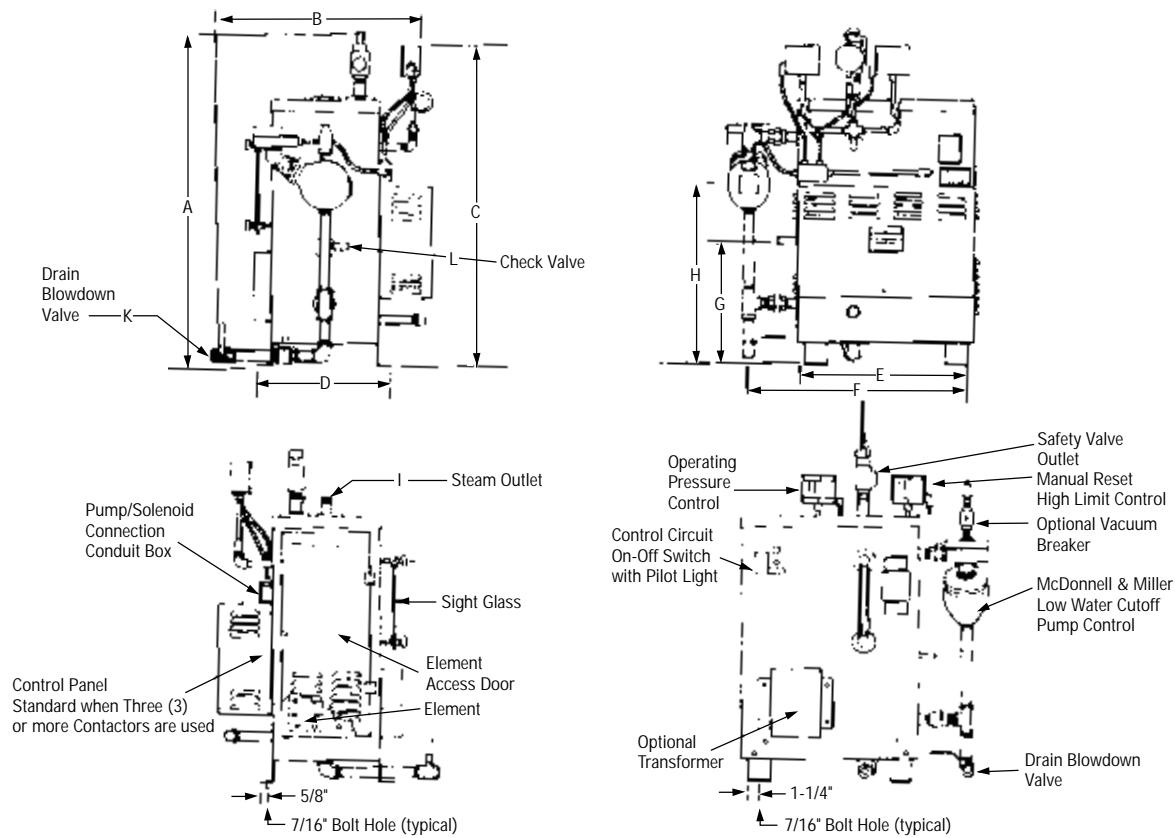

DIMENSIONS

Model	CES — Dimensions (In.)											
	A	B*	C	D	E	F	G	H	I	J	K	L
CES-6	37	22-1/2	30	15-1/4	20	30-1/2	9-1/2	16	1/2	1	1/2	1/2
CES-9	37	22-1/2	30	15-1/4	20	30-1/2	9-1/2	16	1/2	1	1/2	1/2
CES-12	37	22-1/2	30	15-1/4	20	30-1/2	9-1/2	16	1/2	1	1/2	1/2
CES-18	37	22-1/2	30	15-1/4	20	30-1/2	9-1/2	16	1/2	1	1/2	1/2
CES-24	43-1/2	26	46	17-1/2	23	34-1/2	16-1/2	24-1/2	1	1	1	3/4
CES-30	43-1/2	26	46	17-1/2	23	34-1/2	16-1/2	24-1/2	1	1	1	3/4
CES-36	43-1/2	26	46	17-1/2	23	34-1/2	16-1/2	24-1/2	1	1	1	3/4

*Add two inches for transformer.

Model	CES — Dimensions (In.)											
	A	B*	C	D	E	F	G	H	I	J	K	L
CES-48	43-1/2	26	46	17-1/2	23	34-1/2	16-1/2	24-1/2	1	1	1	3/4
CES-60	43-1/2	26	46	17-1/2	23	34-1/2	16-1/2	24-1/2	1	1	1	3/4
CES-72	43-1/2	26	46	17-1/2	23	34-1/2	16-1/2	24-1/2	1	1	1	3/4
CES-100	63-1/2	30	55	21	27	36	16-3/4	37-1/2	1-1/2	1-1/4	1	3/4
CES-135	63-1/2	32	55	20-1/2	26	37-1/2	16	37-1/2	2	1-1/4	1	3/4
CES-160	63-1/2	32	55	20-1/2	26	37-1/2	16	37-1/2	2	1-1/4	1	3/4
CES-180	63-1/2	32	55	20-1/2	26	37-1/2	16	37-1/2	2	1-1/4	1	3/4

INSTALLATION

Note: When installing boiler, allow sufficient room (21" minimum) to facilitate removal of elements if and when necessary.

- The boiler should be mounted on a solid level foundation.
- WARNING:** A minimum distance of 18" between boiler and any combustible material must be maintained.
- Complete all piping to boiler. Connect water line to tagged fitting on the motor and pump assembly, if used, or to tagged fitting on water control feeder.
- When any type of feed other than a pump feed is used — the existing water supply must be 10 pounds greater than the boiler operating pressure to assure water supply maintains proper water level in boiler. Otherwise, lack of water can cause heater failure. Keep feed water line valves open at all times except during blowdown.

- All water feed systems are connected to water inlet check valve.
- Connect steam line (with Globe valve) to boiler steam outlet. Valve should be placed as close as possible to boiler outlet and sized per label on boiler.
- To insure maximum efficiency of supplied kW, all piping from outlet should be insulated.
- Drain and relief valve piping should be in accordance with state and local codes. Floor drain to be provided directly below unit.
- All electrical wiring should be done by licensed electrician in accordance with national and local electrical codes.
- If pump is located less than 30 feet from boiler, a second check valve is required.

Typical Plumbing Installation of a Steam Boiler with Condensate Return System

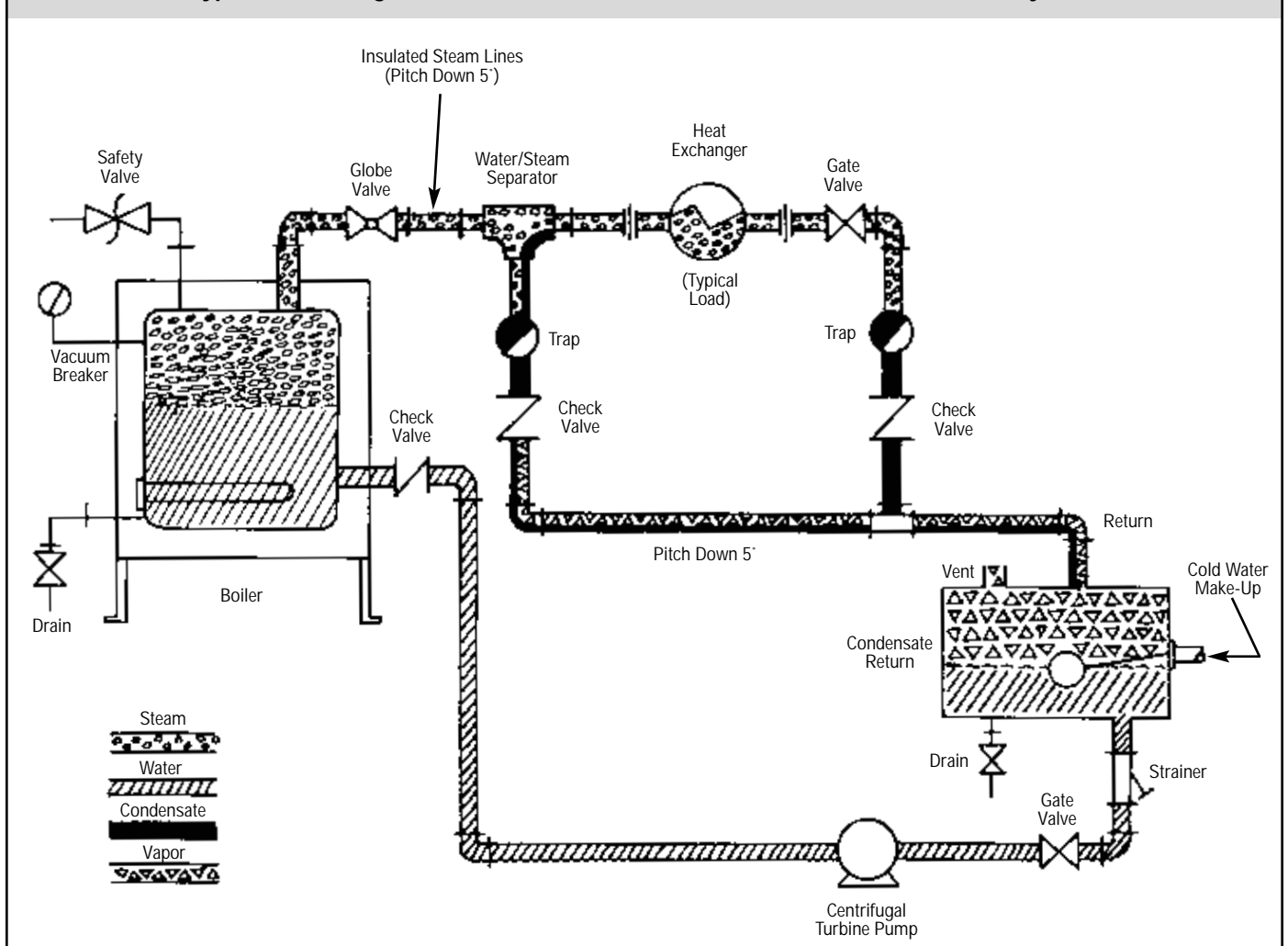

WIRING

WARNING: Hazard of Electric Shock. Boiler must be suitably grounded according to N.E.C. standard.

1. Be sure to use the proper wire. Electric wiring to boiler should be in accordance with National Electrical Code or local wiring code following wiring diagram supplied. (See recommendations on safety switches and fusing.)
2. The unit is completely wired and pre-tested before shipment. No internal wiring is required.
If a separate control circuit is used, the control circuit should be connected to the control terminal block, inside access door (not required with transformer).
3. **Safety Switches** — **WARNING: Purchaser should use a safety switch employing circuit breakers or fuses between his main power source and the boiler.**
4. Because of their water lines, boilers are susceptible to lightning damage. Industrial type lightning protectors should be installed per manufacturer's recommendations at your service entrance. Check

your contractor or electrical dealer for recommended type for your system.

5. Be sure all electrical connections are sufficiently tightened.
6. **WARNING: Substitution of components or modification of wiring system voids the warranty and may lead to dangerous operating conditions.**
7. **SPECIAL INSTRUCTIONS FOR CUSTOMERS SUPPLYING THEIR OWN CONDENSATE OR PUMP SYSTEMS.**
 - A. Check the voltage of the motor before making the wiring connection. Some Chromalox boilers are supplied with dual voltage systems. The motor should always match the voltage of the control circuit.
 - B. The motor circuit should be wired into the pump control as shown in wiring diagram (float type pump control). If boiler is equipped with solid state pump control, refer to wiring diagram and use terminals 5 and 2.

TYPICAL WIRING DIAGRAMS

Use Applicable wiring diagrams based on model number and power voltage.

Boiler	3 Phase Voltage			Boiler	3 Phase Voltage			Boiler	3 Phase Voltage		
	208	240	480		208	240	480		208	240	480
CES-6	1	1	1	CES-30	2	2	3	CES-100	8	8	9
CES-9	1	1	1	CES-36	2	2	3	CES-135		10	11
CES-12	1	1	1	CES-48	4	4	5	CES-160		12	13
CES-18	1	1	1	CES-60	6	6	7	CES-180		10	11
CES-24	2	2	3	CES-72	6	6	7	Export	14		

Diagram 1

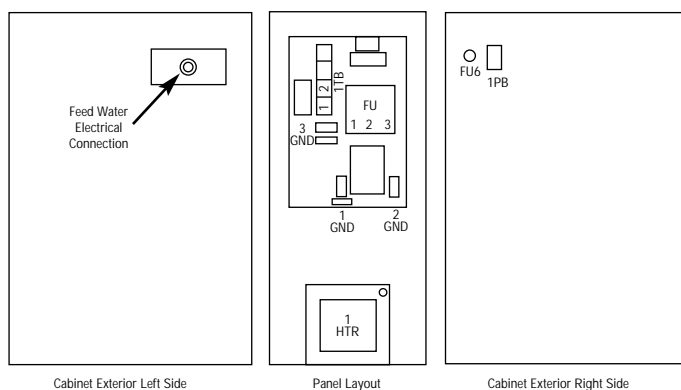

Wire Color Code
 B = Black
 BR = Brown
 R = Red
 O = Orange
 Y = Yellow
 G = Green
 BL = Blue
 W = White

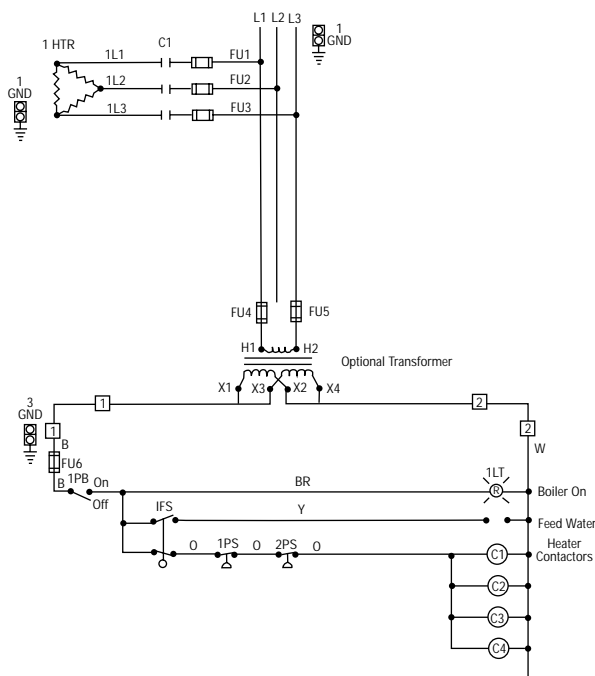

* Boilers under 40 Amps total (not fused)

TYPICAL WIRING DIAGRAMS

Diagram 2

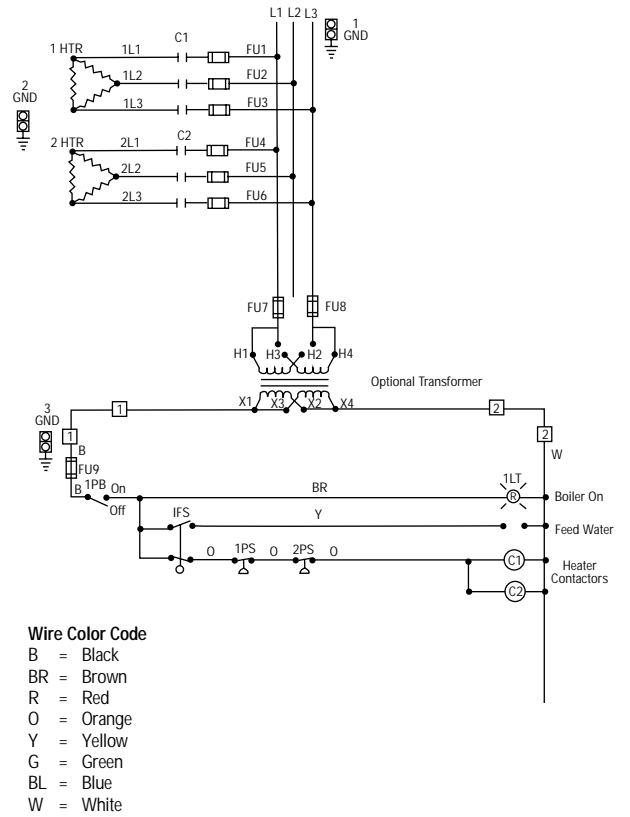
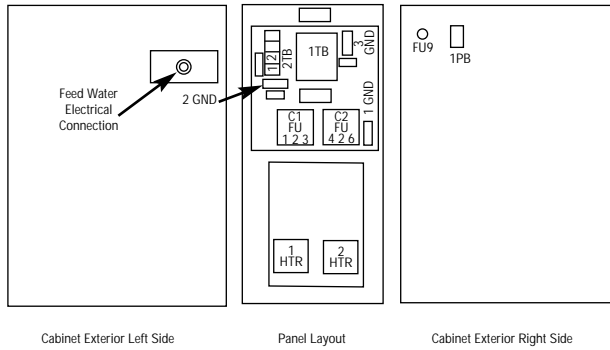
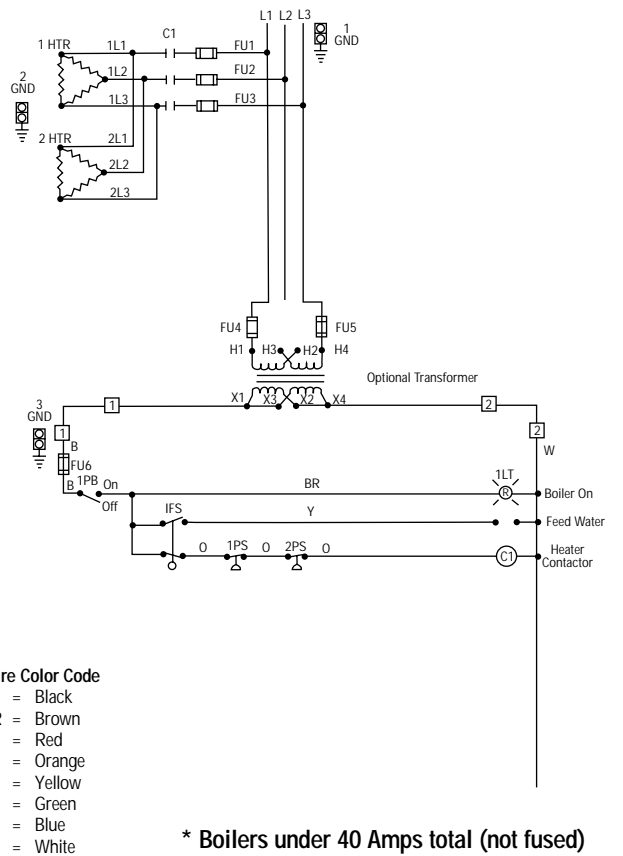
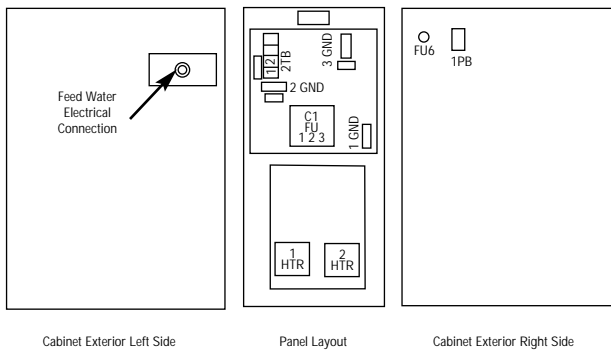
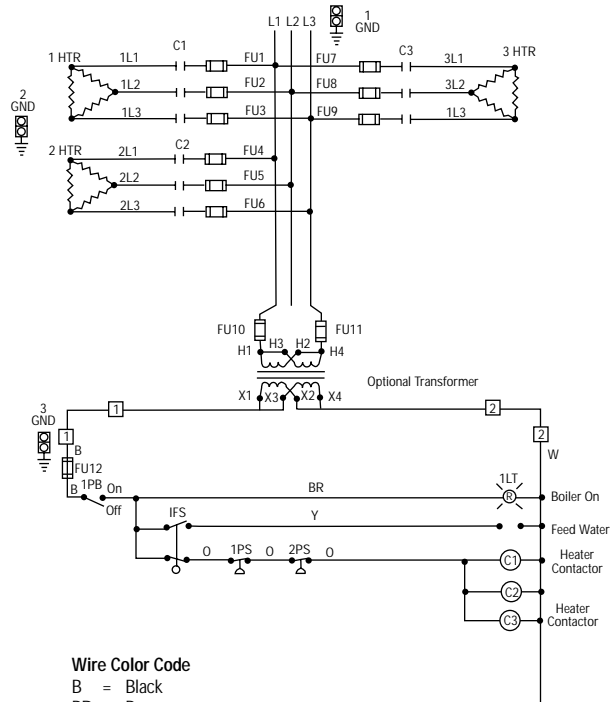
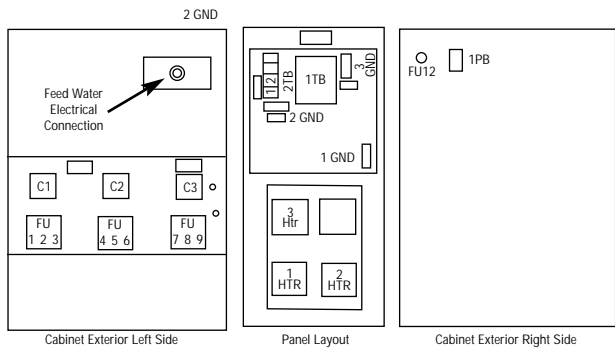

Diagram 3



TYPICAL WIRING DIAGRAMS

Diagram 4



Wire Color Code

- B = Black
- BR = Brown
- R = Red
- O = Orange
- Y = Yellow
- G = Green
- BL = Blue
- W = White

Diagram 5

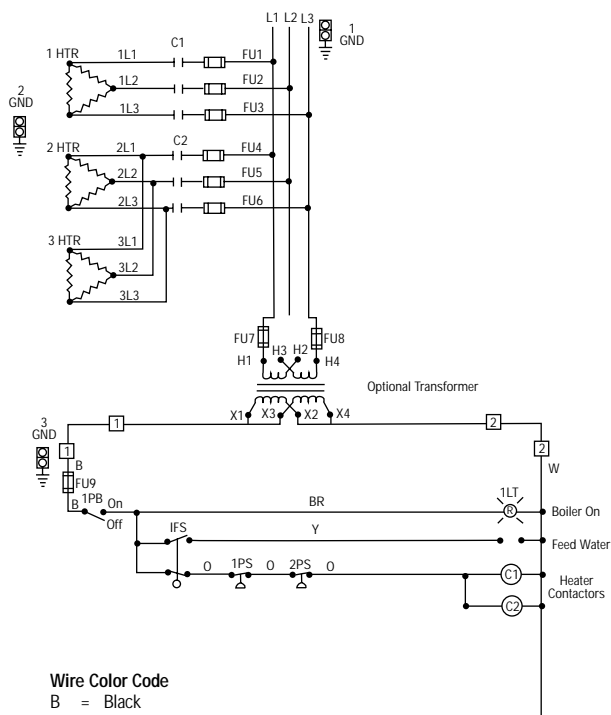
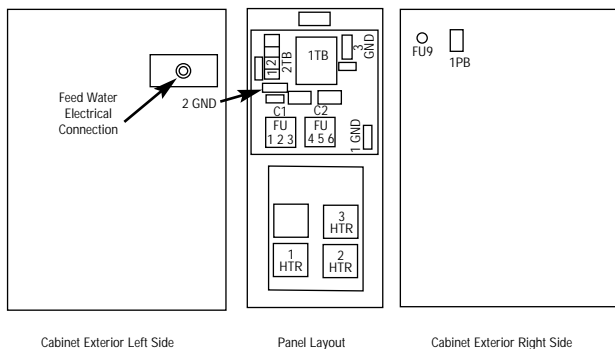

Wire Color Code

- B = Black
- BR = Brown
- R = Red
- O = Orange
- Y = Yellow
- G = Green
- BL = Blue
- W = White

TYPICAL WIRING DIAGRAMS

Diagram 6

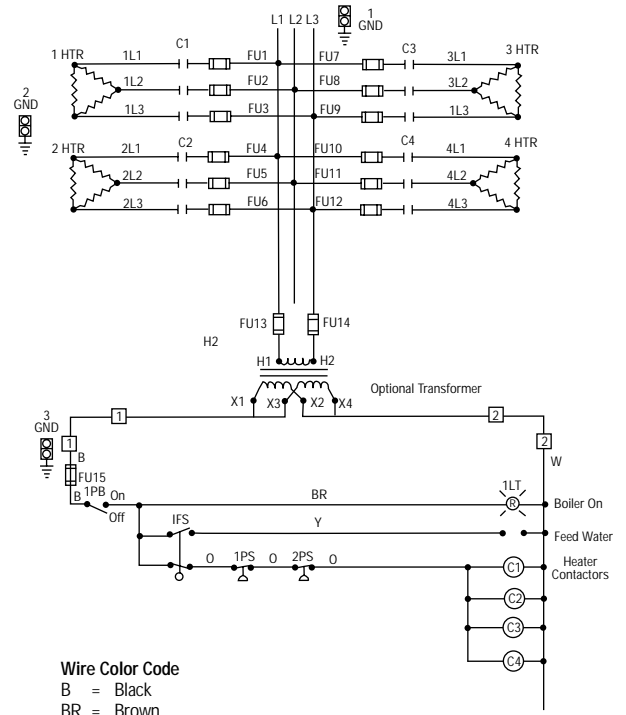
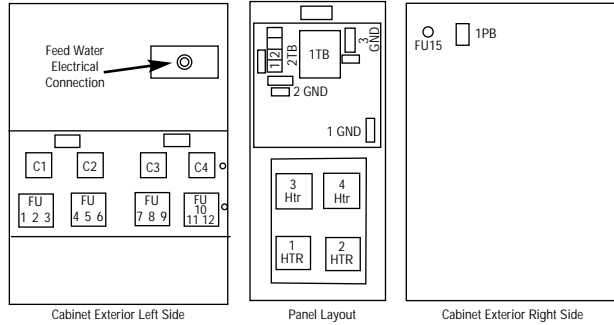

Wire Color Code

- B = Black
- BR = Brown
- R = Red
- O = Orange
- Y = Yellow
- G = Green
- BL = Blue
- W = White

Diagram 7

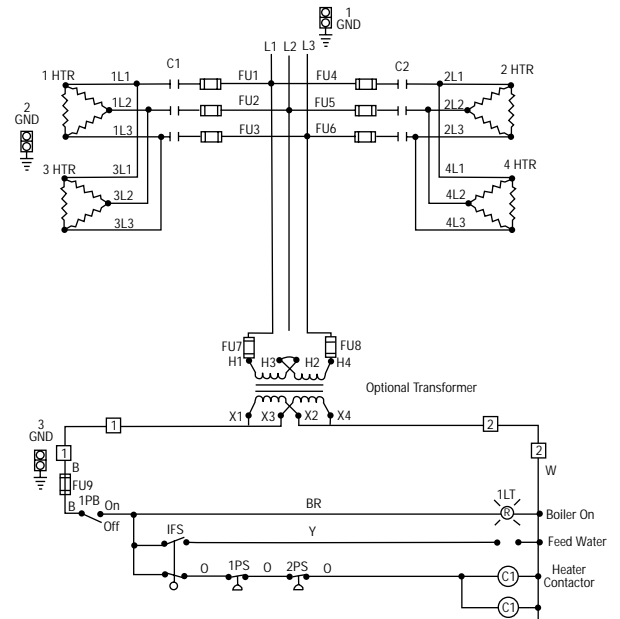
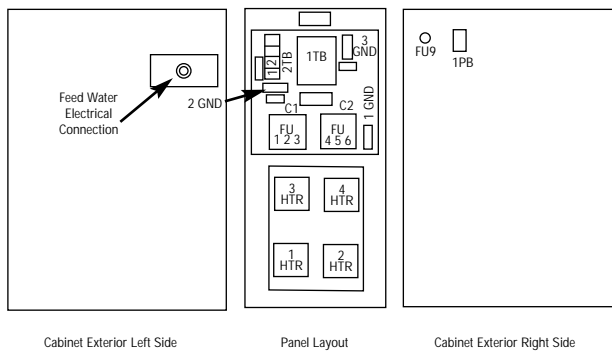

Wire Color Code

- B = Black
- BR = Brown
- R = Red
- O = Orange
- Y = Yellow
- G = Green
- BL = Blue
- W = White

TYPICAL WIRING DIAGRAMS

Diagram 8

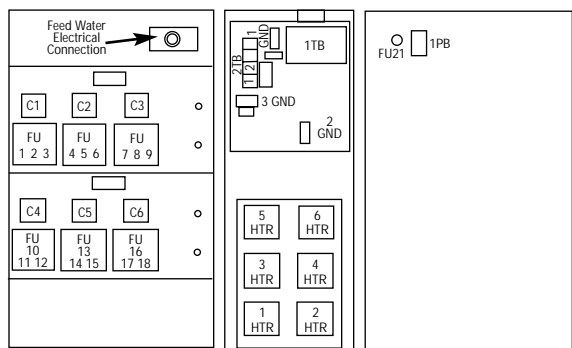

Cabinet Exterior Left Side

Panel Layout

Cabinet Exterior Right Side

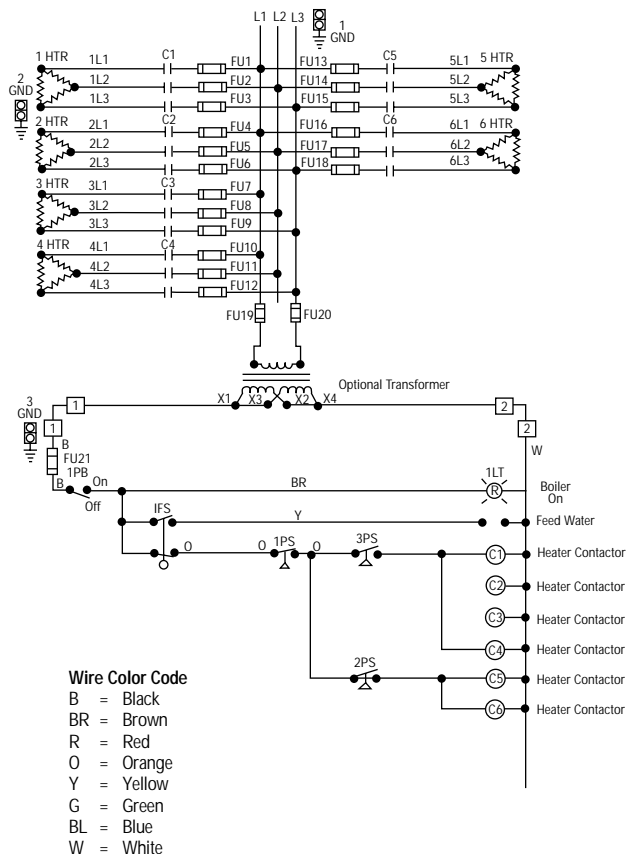
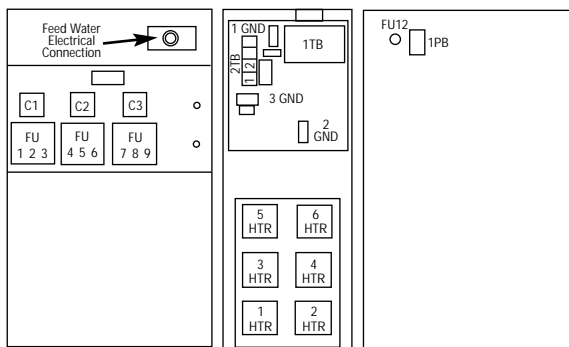

Diagram 9



Cabinet Exterior Left Side

Panel Layout

Cabinet Exterior Right Side

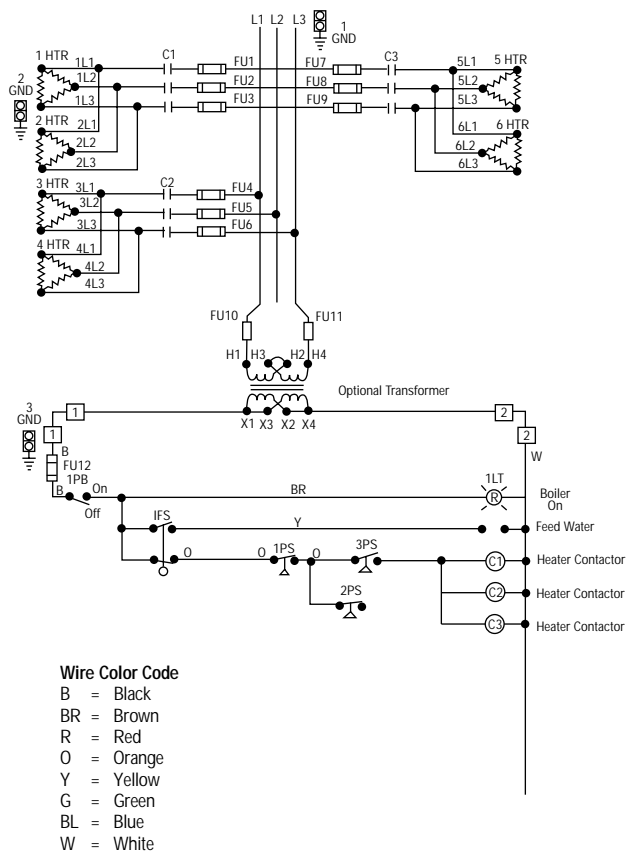

TYPICAL WIRING DIAGRAMS

Diagram 10

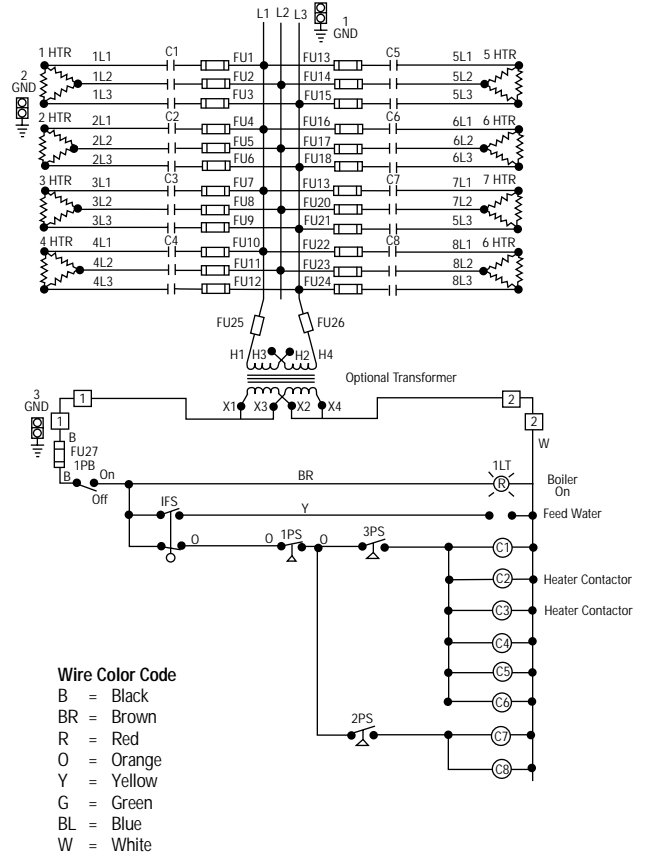
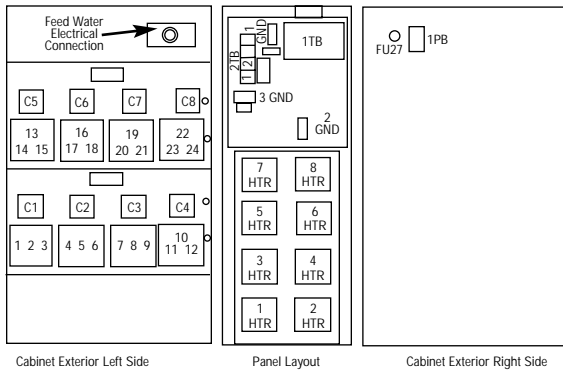
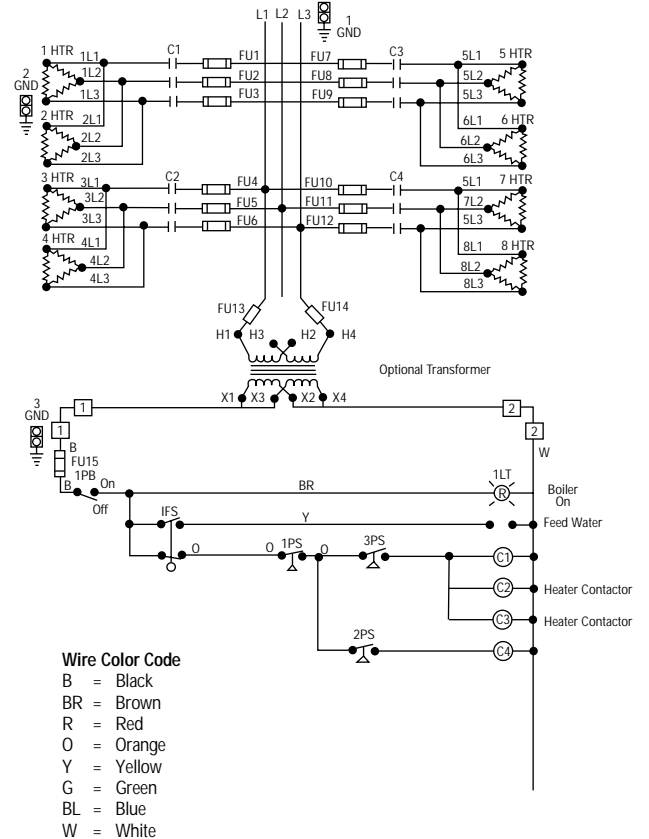
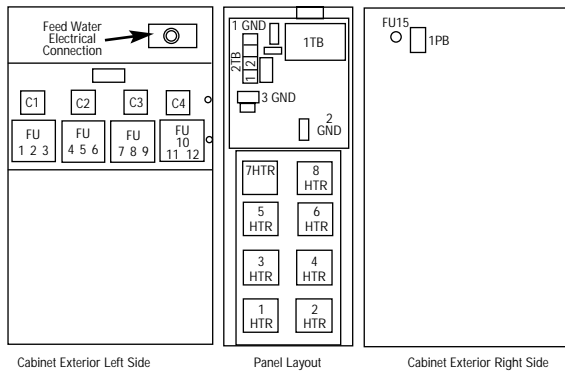

Diagram 11



TYPICAL WIRING DIAGRAMS

Diagram 12

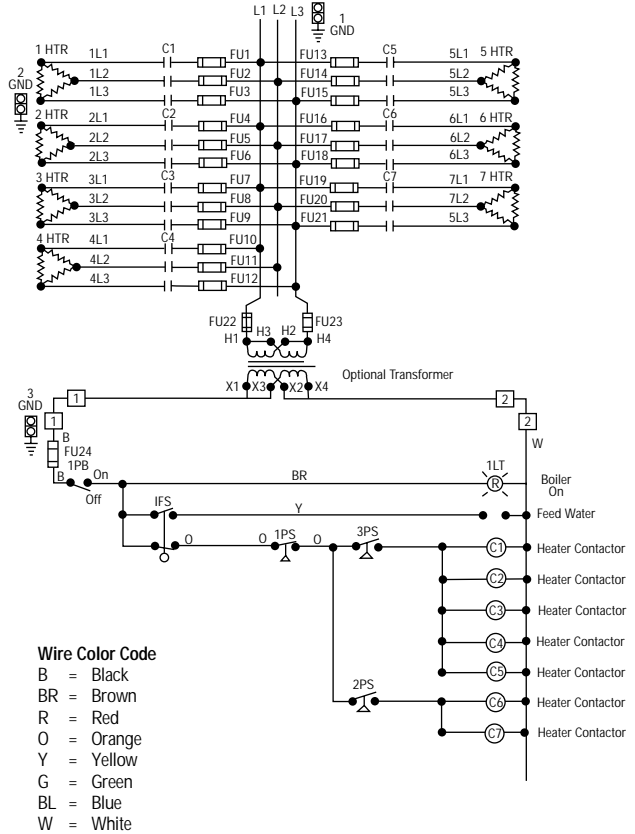
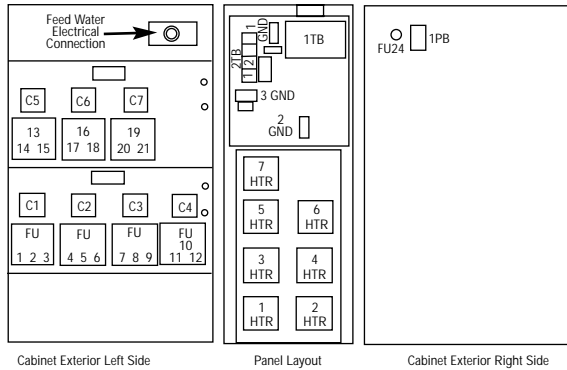
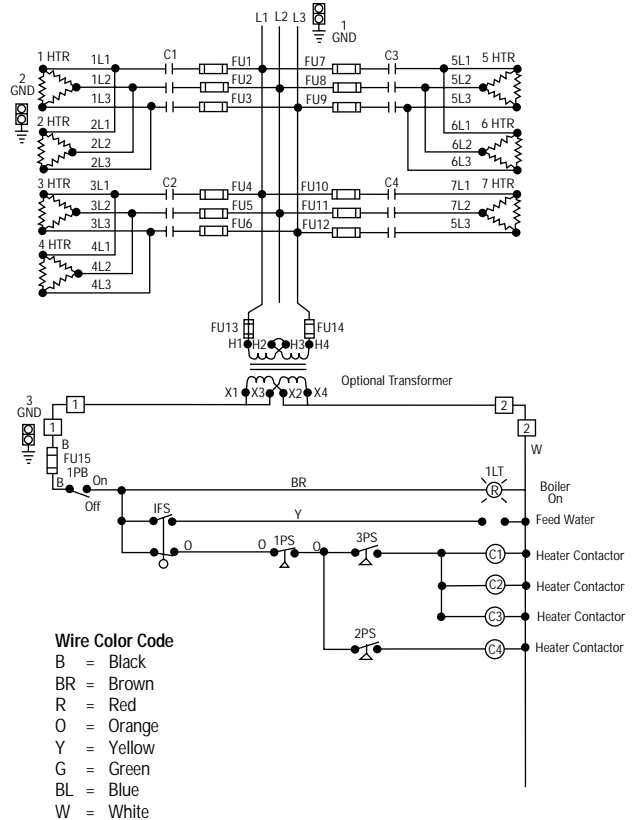
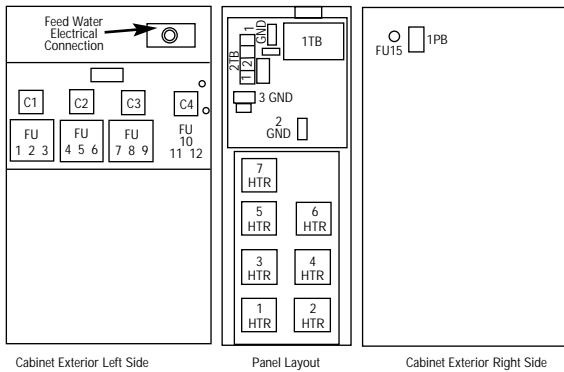
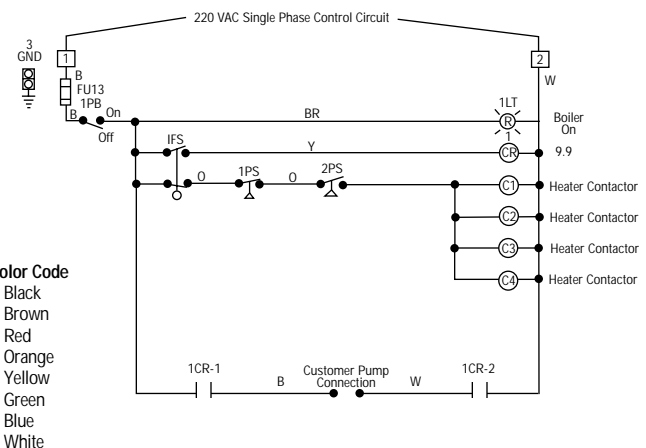
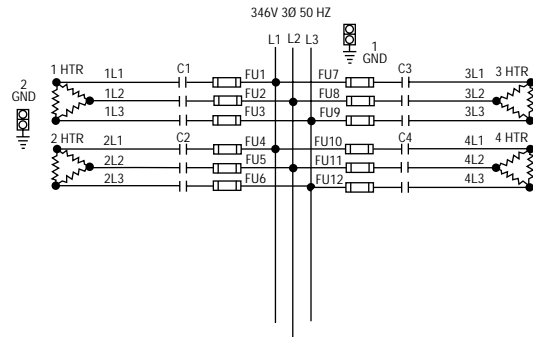
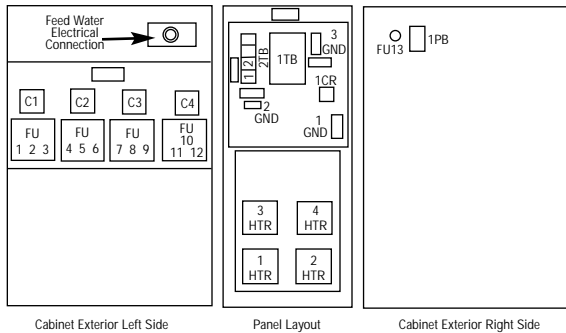

Diagram 13



TYPICAL WIRING DIAGRAMS

Diagram 14
Typical Export Boiler



PRE-OPERATION CHECK

After proper wiring and piping of boiler system is complete, testing of controls can start. **Before testing controls, it is recommended that all contactor fusing be removed.** This is to prevent possible element failure under test conditions.

A. OPERATING AND TESTING THE McDONNELL & MILLER LOW WATER CUTOFF CONTROL.

1. Be sure all valves from incoming water supply are fully open. **Turn boiler switch to "ON" position**, pump or solenoid valve will energize, allowing boiler to fill with water. Proper water level is automatically reached with level control supplied. Pump or solenoid feed will shut off at proper water level. Contactor(s) will energize, supplying power voltage to elements.
2. **Checking operation of pump switch.** (Figure 1) With water level visible in sight glass, partially open drain valve at bottom of boiler. If automatic blowdown supplied, push manual blowdown switch until valve open light is on, hold for few seconds. Water level will fall, allowing float to trip pump switch to "ON" position. Close drain valve or release manual blowdown switch. Pump motor or solenoid valve will energize and water level will resume to normal level in sight glass.
3. **Checking low water cutout switch operation**, open drain valve completely. If automatic blowdown supplied, push in and hold manual blowdown switch until water level falls enough to trip cutout switch. Close drain valve or release manual blowdown switch. If low water cutout is automatic reset, pump or solenoid will return water level to normal. If low water cutout is manual reset, then manual reset button on McDonnell & Miller low water cutoff control must be pushed to complete circuit. **Turn off boiler. Reinstall contactor fuses.**

WARNING: Be sure all electrical connections are tight before energizing boiler. Reset all manual reset controls by pushing reset buttons on: (1) high limit control located on top of boiler and (2) McDonnell & Miller located on the side of boiler.

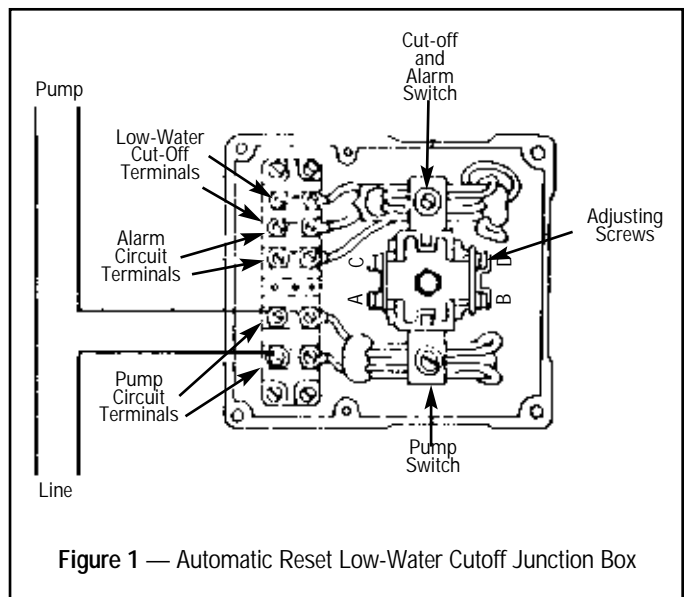

Figure 1 — Automatic Reset Low-Water Cutoff Junction Box

OPERATION

ADJUSTING OPERATING PRESSURE CONTROLS

1. Chromalox boilers are supplied with operating and high limit pressure controls. One is used for controlling the operating pressure of the boiler while the other is used as a high limit control. To determine the difference in the controls, the high limit has a manual reset lever on top of the case. Also, there is no differential scale present.
2. On all controls, the pressure adjusting screw on the top of the case sets the desired pressure. Turning the screw counterclockwise reduces the pressure setting (**CUT OUT**) (See Figure 2). High limit control should be set at 10 psig above the operating pressure of the boiler.
3. The differential adjusting screw on the operating control is set in the same manner as the pressure adjusting screw. The **CUT OUT** setting minus the differential setting, equals **CUT IN** pressure of the operating control.

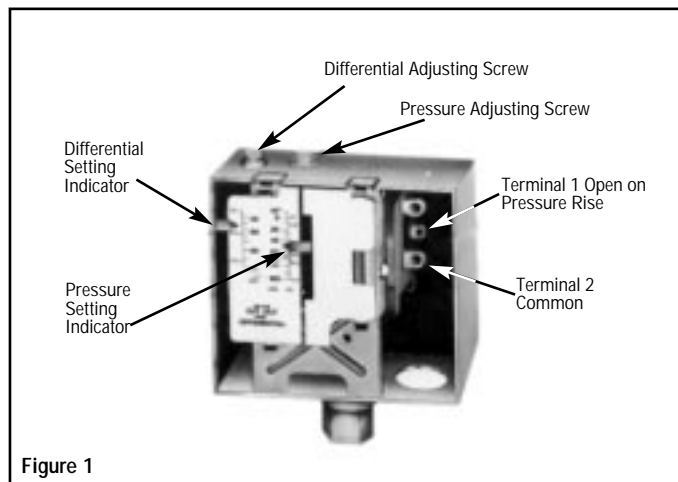

Figure 1

CES-12 through CES-72, one pressure control supplied; CES-100 through CES-180, two pressure controls supplied.

To check operation of the controls, close steam outlet valve and adjust operating pressure control to a low pressure setting. Also, set high limit control at 10 psig above operating pressure control. Turn on boiler, and allow pressure to build up. When pressure gauge reading approaches set point of pressure control, the switch will trip and shut off boiler. Turn off boiler.

To reset pressure control, bleed off enough pressure in the boiler by opening steam outlet drain, or blowdown valve to allow the operating control to reset.

4. HIGH LIMIT PRESSURE CONTROL OPERATION

The high limit is tested in the same manner but with the operating control set above the pressure setting of the high limit. (Figure 3)

CAUTION: This is for test purposes only!

When the high limit trips, turn off boiler and reset high limit to proper setting. The manual reset level must be pushed to resume operation upon startup.

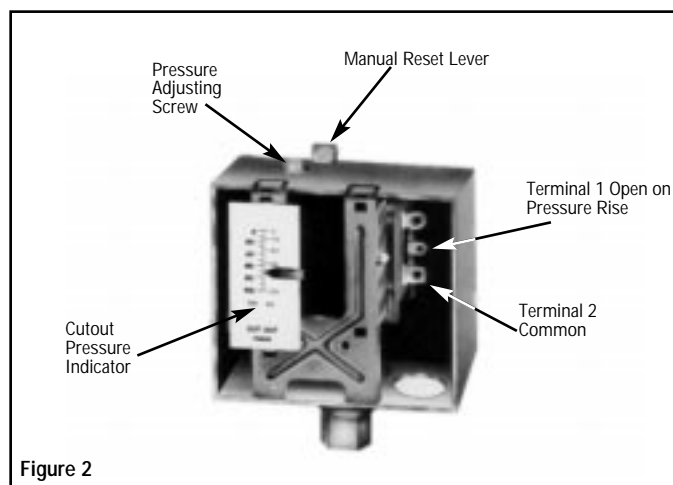

Figure 2

OPERATION

RECOMMENDED START-UP PROCEDURES

1. Close globe valve on steam outlet side of boiler. (Customer Supplied)
2. Turn on boiler and allow pressure to build up to operating pressure.
3. Only open globe valve at quarter turns at first, introducing smaller amounts of steam into process. Avoid opening globe valve all at once. This will eliminate the possibility of evacuating the boiler of water caused by the suddenly increased boiling of the water in the vessel as the pressure is reduced. On boilers where constant pressure is not maintained, globe valve should be kept partially closed. This will maintain a constant head on the boiler and stabilize any fluctuation in boiler water level.

Note: For best boiler performance, a 1/4" less steam valve than size of safety valve should be plumbed as close as practicable to steam outlet. Where 1/2" safety valve is used on boiler, a 1/4" steam valve is recommended.

MANUAL BLOWDOWN INSTRUCTIONS

Blowdown is an essential part of boiler operation. It is the best preventative maintenance you can give your boiler and will add years of life to the unit. Make sure a blowdown schedule is established and followed regularly.

In extremely hard water areas, blowdown is necessary once a day. In soft water areas, once each week. If there is a particular problem which applies to your own local water condition other

than mineral content, take this into consideration in determining which schedule is to be followed.

1. At end of the working day, while boiler is still operating, turn switch to the OFF position and close water supply valve. De-energize wall mounted safety switch.
2. If blowing-down into a receptacle, allow pressure to decrease to 15-20 psi before opening blowdown valve.
3. It is preferable to connect the blowdown valve directly into a drainage system. If this is done, the boiler can be discharged at operating pressure.
4. When discharge is complete and boiler is drained — (a) close the blowdown valve; (b) open water supply valve; (c) put boiler switch in the ON position; and, (d) close wall mounted safety switch.
5. When refilling is complete, turn off the boiler switch unless further operation is desirable.
6. If you have been supplied with a Manual Reset Low Water control as required in some states, the reset button on the control must be pushed before boiler will begin developing pressure. (Do not push reset until boiler has filled with water.)

The use of chemical boiler cleaning compounds in these boilers voids all warranties unless approved by manufacturer. Some compounds will damage copper sheathed heating elements to shorten useful life.

OPERATION

AUTOMATIC BLOWDOWN INSTRUCTIONS (IF FURNISHED)

The Automatic Blowdown is a device which automatically starts up your boiler in the morning; shuts it down at night and blows down (partially drains) the main boiler drain and the low water cut-off column for a predetermined time interval each working day.

The heart of the unit is an electrically operated straight through type ball valve. It is specially designed to handle dirty, corrosive fluids and particles without requiring cleaning or the use of a strainer.

Both the valve and the boiler are controlled by an electric control unit which indicates with pilot lights when the drain valve is in the opened or closed position and when the boiler is ON or OFF. In addition to the automatic control function, the unit has a push button which momentarily de-energizes the boiler and opens the drain valve regardless of the time of day.

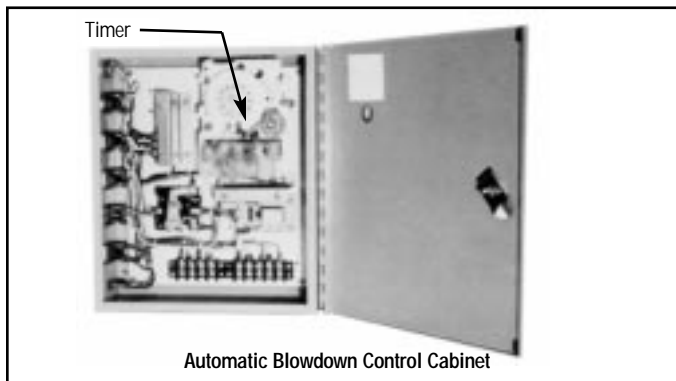

Automatic Blowdown Control Cabinet

The unit may also be used to blow down boilers which run continuously, day and night.

INITIAL TESTING — Set the switch marked “Programmed duty/24 Hour duty” located on the panel box to the “ON” position.

On the large timer set the “ON” tab at about 8 AM and the “OFF” tab at about 8 PM. Set the blowdown cycle dial at “O”.

Turn the large timer by hand until the “ON” tab passes the “TIME NOW” indicator so the “TIME NOW” arrow indicates 10 AM.

Energize the main feed to the “LINE TERMINALS” of the unit. The “BOILER ON” pilot light as well as the “VALVE CLOSED” light should glow.

Hold down the “DRAIN” button for about six seconds. The “BOILER ON” light should go out immediately as well as the “VALVE CLOSED” light. It takes about 4 seconds for the drain valve to open fully at which time the “DRAIN VALVE OPEN” light should light. As soon as the “DRAIN” button is released the valve begins to close. When it reaches the closed position, the “VALVE CLOSED” and the “BOILER ON” should light up again.

Now turn the wheel on the large timer until the “OFF” tab passes the “TIME NOW” arrow. The “BOILER ON” light should go out and the valve should begin to open. Once the “VALVE OPEN” light goes on, the valve should remain open for a few seconds and then automatically close. The “VALVE CLOSED” light should light and the “BOILER ON” light should remain off.

OPERATION— Set the “BOILER PROGRAMMED DUTY” switch to “BOILER ON” if the boiler is to be shut down each night. Set it to “24-HOUR DUTY” if the boiler is to remain on continuously 24-hours per day (except during blowdown).

Set the tabs on the large timer for the ON and OFF times desired for the boiler, screw in the small black day-skip tabs if it is to remain off during the weekend, etc.

If the boiler is on 24-hour duty, set the OFF tab for the time that is desired for blowdown. the ON tab can be ignored, but must remain on timer.

The small time delay relay controls the time that the drain valve remains open. The time is controlled by adjusting knob marked Blowdown cycle. Counterclockwise decreases, clockwise increases blowdown time. Time must be adjusted by trial.

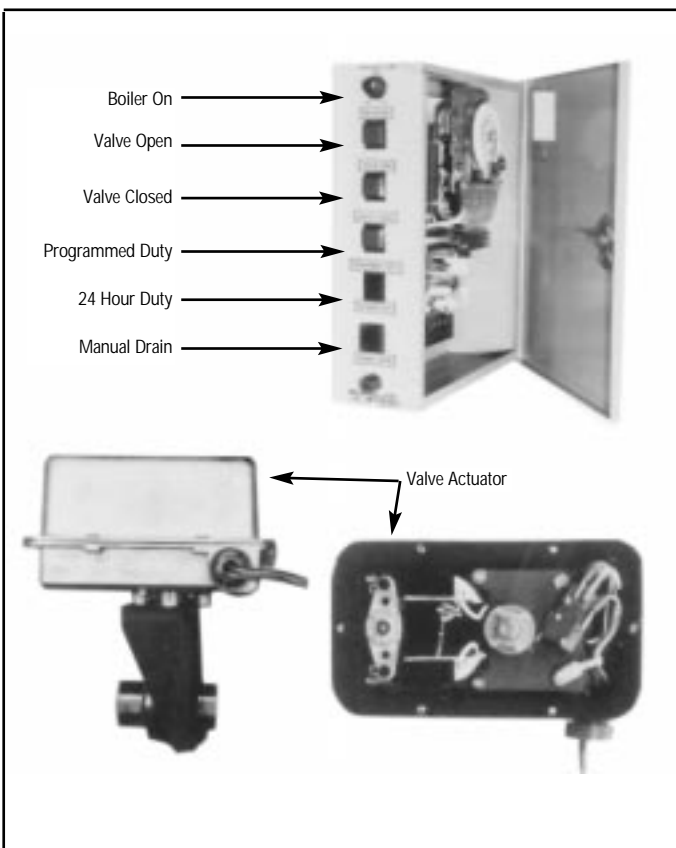

Display View of Automatic Blowdown Control Cabinet

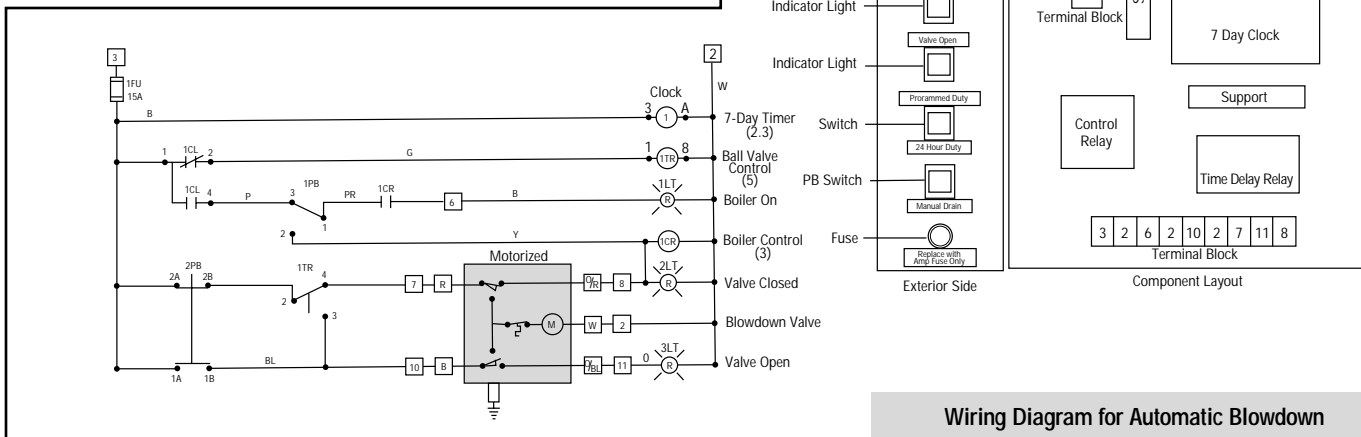

Wiring Diagram for Automatic Blowdown

OPTIONAL EQUIPMENT FOR STEAM BOILERS

AUXILIARY LOW WATER CUTOFF

Operation

Operation of this control is accomplished by sensing a minute AC current flowing between submerged contact probe in the boiler shell.

When this minute AC current is conducted through an external circuit resistance up to 40,000 ohms or less, a signal of sufficient magnitude is present to trigger the SCR and, in turn energize the control relay.

As the water level in the boiler drops below the level of the probe, the AC current is broken and the control relay is de-energized. The control will not energize until sufficient water is present in the boiler. Optional manual reset may require reset prior to heaters being energized after level 13 brought to normal.

WARNING: Control will not work with de-ionized or demineralized water.

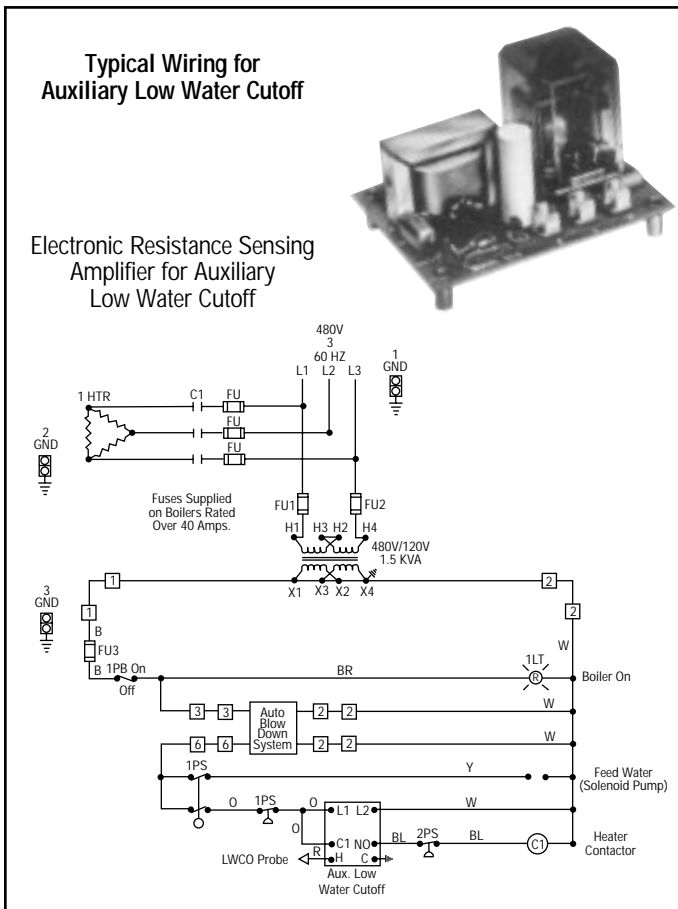

PROPORTIONING PRESSURE CONTROL FOR SEQUENCER AND SCR CONTROLS

Typical Operation

Pressure variations cause the bellows to expand or contract. Linkage between the bellows and the potentiometer wiper causes the wiper to move across the windings on the potentiometer. This varies the resistance between R and B, and between R and W, causing an unbalance in the circuit connected to the controller.

A proportioning pressure control is used to regulate a motor driven or solid state sequencer. The controller potentiometer, the feedback potentiometer in the motor and a balancing relay in the motor form an electric bridge circuit. As long as the pressure of the controlled medium remains at the set point of the controller, the circuit is balanced; i.e., equal currents flow through both sides of the balancing relay and the relay contacts are open. When the circuit is balanced, the motor does not run.

If the pressure of the controlled medium rises, the wiper in the controller moves toward W. This unbalances the circuit so a larger current

flows through one side of the balancing relay. The “close” contacts in the relay make, causing the motor to drive toward its closed position. As the motor runs, the wiper on the feedback potentiometer moves in a direction to balance the circuit. When the circuit is again in balance, the balancing relay contacts open and the motor stops.

Similarly if the pressure of the controlled medium falls, the wiper on the controller potentiometer moves toward B, and the “open” contacts in the balancing relay make. The motor drives towards its open position until circuit balance is achieved.

The slightest change in the pressure of the controlled medium will cause a change in the number of elements energized to compensate for it, thus keeping the pressure constant. This process is called modulation.

PROPORTIONAL PRESSURE CONTROL ONLY SUPPLIED WITH SEQUENCER

Main Setting — Turn the adjustment screw until the indicator is opposite the low point of the desired throttling range. That is, if the pressure is to be held at a minimum of 50 psi, set the indicator at 50 psi. The pressure will then be maintained between 50 psi and a higher pressure equal to the 50 psi plus the throttling range.

THROTTLING RANGE SETTING (L91B)

After setting the indicator for the minimum pressure, turn the throttling range adjustment screw until the throttling range indicator points to the desired throttling range on the scale. This scale is graduated from “min” to “F”. The value of each division varies with the scale range of the instrument.

PRESSURE SCALE RATING	VALUE EACH DIVISION ON SCALE
0-15 psi	2.2 psi
5-150 psi	3.6 psi

Pressure scale rating will vary depending on pressure control supplied.

CHECKOUT

After the controller has been installed, wired, and set, it should be tested with the system in operation. First allow the system to stabilize. Then observe the operation of the controller while raising and lowering its set point. Pressure should increase when the set point is raised and decrease when the set point is lowered. Use accurate pressure testing equipment when checking out the controller. Do not rely on inexpensive gauges. The controllers are carefully calibrated at the factory.

If the motor or actuator runs the proper direction when the set point is adjusted, it can be assumed that the controller is operating properly. If it runs in the wrong direction, reverse the B and W wires. Observe the action of the motor to see if it stabilizes. If the motor is moving constantly, widen the proportioning range a little at a time, until the system is stable.

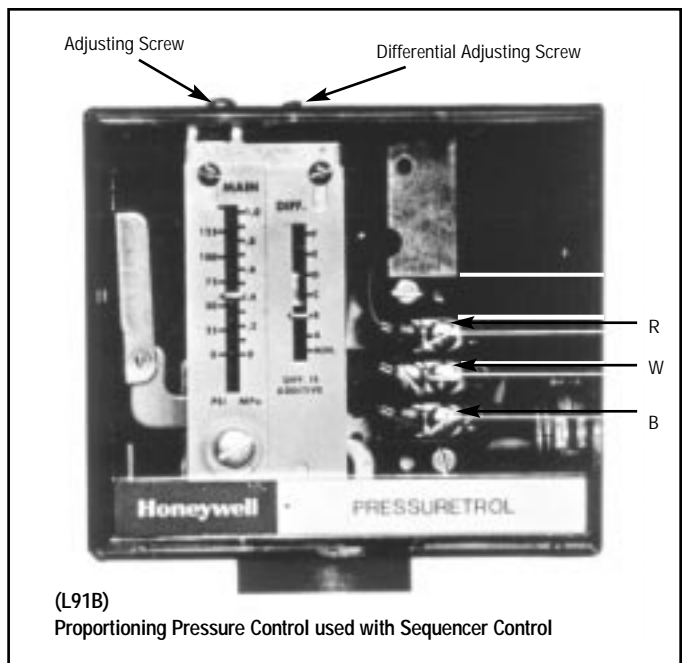

OPTIONAL EQUIPMENT FOR STEAM BOILERS

IF A CONTROLLER SEEMS TO OPERATE IMPROPERLY

If the controller is suspected of operating improperly, it may be further checked as follows:

1. Leave the controller installed where it is, but disconnect all power to the boiler.
2. Loosen the cover screw below the main scaleplate and remove the cover.
3. Disconnect the wires from the controller.
4. Connect an ohmmeter between controller terminals B and W to measure the resistance of the potentiometer in the controller. The ohmmeter should read about 135 ohms on an L91B.
5. Connect the ohmmeter between controller terminals W and R and raise the set point of the controller above the actual pressure being measured. The ohmmeter should read the full value of the potentiometer measured in step 4 (135 ohms for an L91B).
6. Slowly lower the set point of the controller while observing the ohmmeter reading. The resistance should drop to zero at some set point below the actual pressure.
7. An approximation of the proportioning range can be made by observing the change in set point required for a resistance change from zero to full value.
8. When the controller is operating properly, reconnect the wires, replace the cover, tighten the cover screw, and reset the controller to the desired value.
9. Reconnect power to the controlled motor.

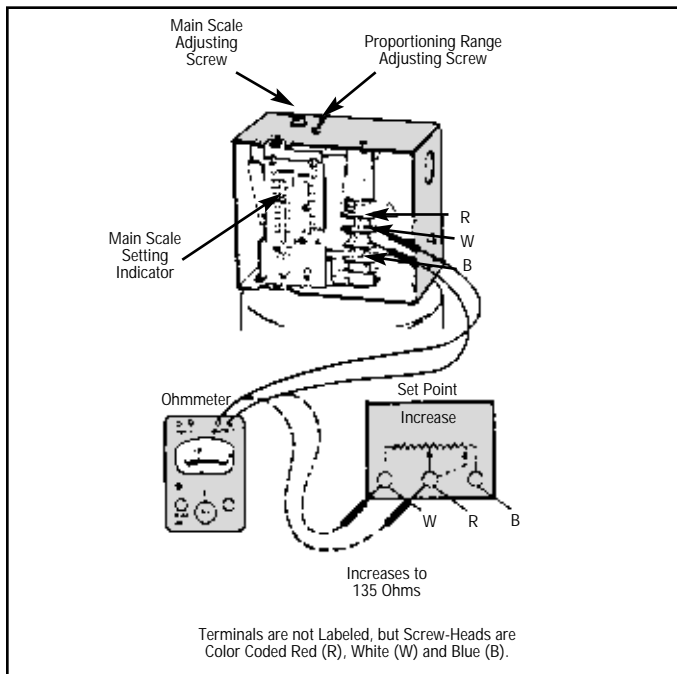

BOILER SEQUENCE — SOLID STATE

Solid State Progressive Sequencer

The solid state progressive sequencer provides accurate electronic control of multi-stage loads of the type used in Chromalox steam boilers. It features progressive sequencing (first on-first off) which equalizes the operating time of each load. This control gives visual indication of each energized stage by means of integral solid state light emitting diodes. In the event of power interruption, all heating elements are immediately de-energized for safety. When power resumes, the control will restage the loads one at a time.

The solid state sequencer operates on 120V AC/60 Hz and each output is relay switched with a load rating of 125 VA at 120V AC.

The input to the sequencer is a 0-135 OHM potentiometer supplied on the operating pressure control. The sequencer has a sensitivity control which is adjustable from min. to max. This sensitivity control defines the amount of resistance (pressure) deviation allowed before adding or subtracting a load. Potentiometer resistance should decrease with increasing pressure. Connections are made to red and white terminals of proportional pressure control. See Wiring Diagram 337-300164-452 for Boiler With Solid State Sequencer.

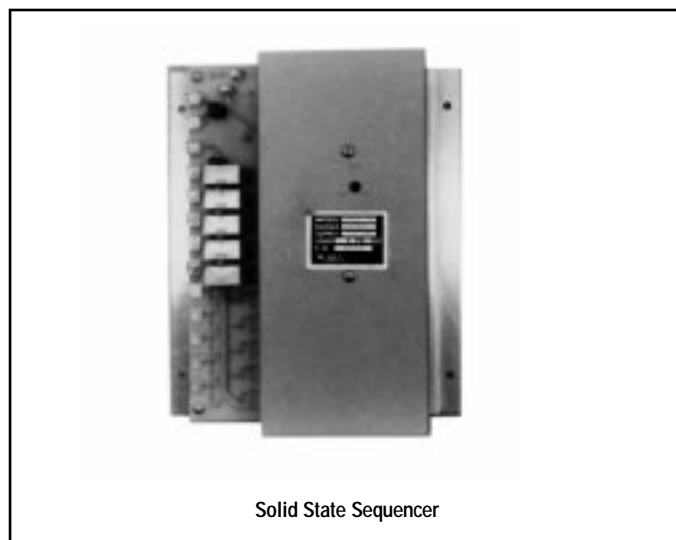

Typical wiring for boilers equipped with Auto Blowdown System and/or Solid State Sequencer.

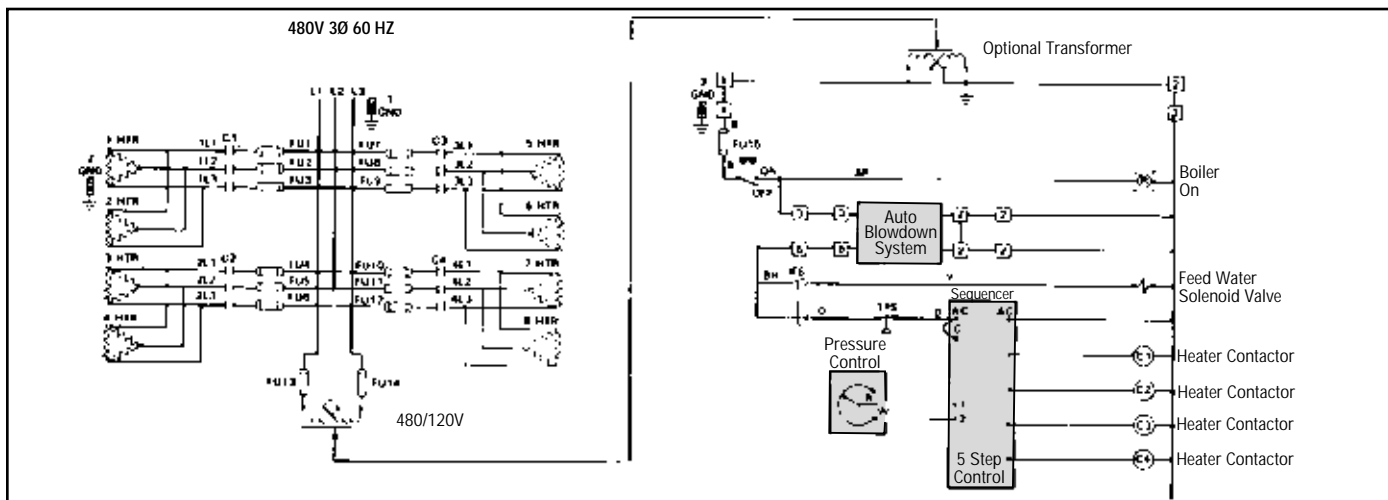

WATER FEED SYSTEMS

Automatic water feed is required on all CES Boilers:

LOW PRESSURE FEED

Note: Water Pressure feeds must be at least 10 psi greater than steam pressure.

Boiler	Low Pressure (Solenoid Feed)	Volts	Inlet (In.)	Pressure Range
CES Series	ES-99117	120	1/2	0-100 psi



Automatic Low Pressure Water Feed

Low pressure water feed systems are used to supply make up water to the boiler where incoming water line pressure is 10 psig or greater than the operating pressure of the boiler. It consists of strainer, solenoid valve and check valve.

Installation

The low pressure water feed systems are optional, and are factory plumbed and wired to the boiler. However, CES series boilers which are shipped from stock, the ES-99117 feed is shipped separately for field installation.

Field Installation

Note: The low pressure feed is to be plumbed to the inlet of the factory mounted check valve located on the make up water inlet to the boiler. The plumbing and wiring are to be conducted by licensed personnel in accordance with national and local electrical codes. For wiring refer to wiring diagrams supplied with the boiler.

HIGH PRESSURE FEED

High pressure makeup water pumps are used when water pressure does not exceed boiler pressure by more than 10 psi and when condensate water is not returned to the boiler. **Note:** Consult factory or sales office for motor/pump sizing for appropriate water feed system.

WARNING: Hazard of Electric Shock. Water feed system must be effectively grounded in accordance with the National Electrical Codes to eliminate shock hazard.

Installation

1. Locate feed on level floor or platform.
2. Connect water line to tagged fitting on feed.
3. Connect piping from discharge to water inlet check valve on boiler with minimum of 90° bends or other restrictions.
4. All electrical wiring should be done by licensed electricians in accordance with local and national electrical codes. Refer to boiler instruction for manual wiring diagram.
5. If pump is located less than 30 feet from boiler, a second check valve is required.

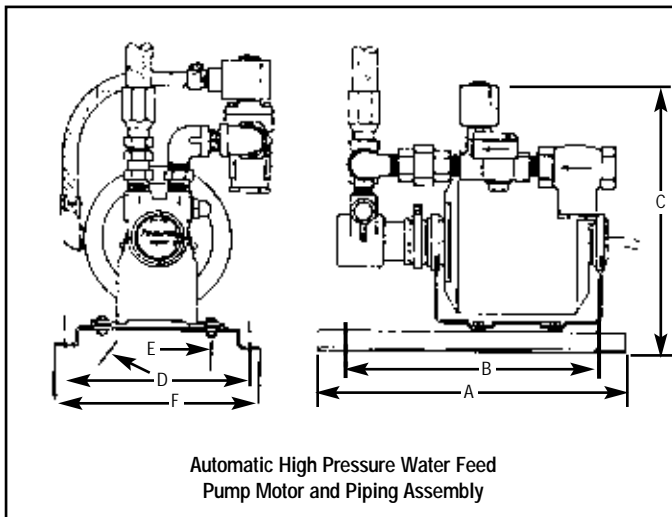

Automatic High Pressure Water Feed
Pump Motor and Piping Assembly

Pump Motor Dimensions

Assembly Model No.	H.P.	Pressure Range	Pipe Size NPT	Dimensions (In.)					
				A	B	C	D	E	F
ES-38002	1/3	0-100	1/2"	12	10	11	7-3/8	6-1/2	7-1/2
ES-38020	1/2	0-150	3/4"	12	10	11	7-3/8	6-1/2	7-1/2

CONDENSATE RETURN SYSTEMS

Chromalox condensate return systems are used wherever condensed steam can be collected for reuse in the boiler. Significant energy can be saved by returning condensate to the boiler. The condensed water is free from corroding minerals and carries a substantial amount of heat which does not have to be replenished.

IMPORTANT: Vacuum breaker is required whenever using a condensate return system.

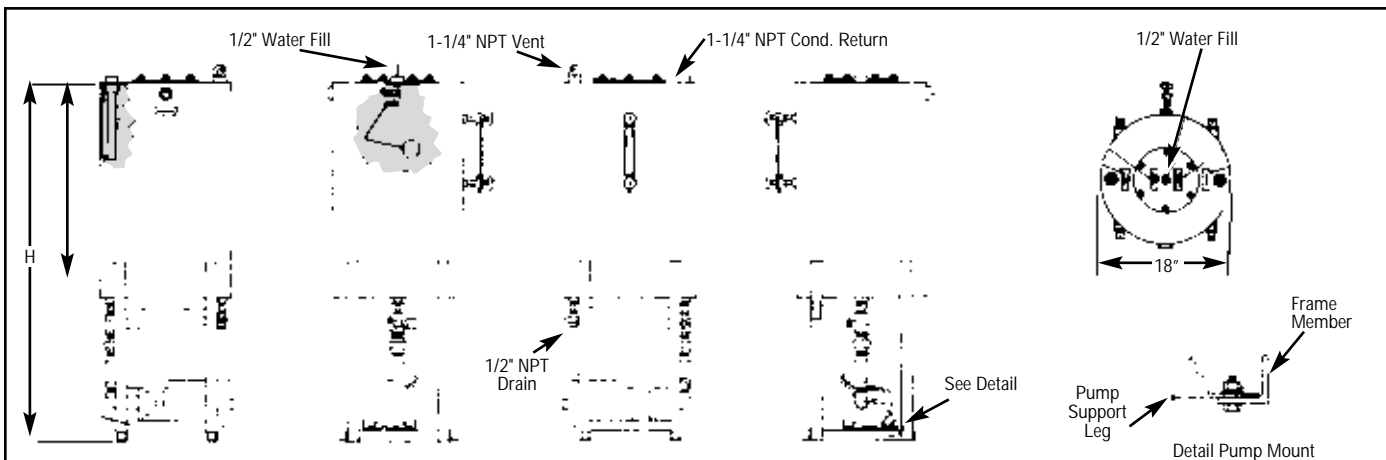

26 and 33 Gal. Condensate Return System

Condensate Model	For Boiler Model	Max Pressure (psig)	Storage Tank Capacity (Gals.)	Pump (hp)	Motor (Volts/Phase)	Pump Discharge Conn. (NPT)	Condensate Ret. Conn (NPT)	Dimensions (In.)		
								L	H	W
ES38083V	CES 12 - 72	100	26	1/3	120 1	1	1	23	46	18
ES38084V	CES 100 - 180	100	33	1/2	120 1	1	1	23	52	18

WATER FEED SYSTEMS

Installation

Wiring

- A. Check the voltage of the motor before making the wiring connection. Some Chromalox boilers are supplied with dual voltage systems. The motor should always match the voltage of the control circuit.
- B. The motor circuit should be wired into the pump control located on the boiler. See boiler instruction sheet for wiring diagram.C. All electrical wiring should be done by licensed electrician.

- D. Be sure to use the proper wire. Electrical wiring to boiler should be in accordance with National Electrical Code or local wiring code following wiring diagram supplied.

Plumbing

- A. Connect water line to tagged fitting on the motor and pump assembly control feeder.
- B. Interconnecting piping between boiler and condensate return system should be installed with a minimum of 90° bends or other restrictions.

MAINTENANCE

WARNING: Hazard of Electric Shock. Disconnect all power before working on boiler.

Chromalox Electric Steam Boilers are designed for years of trouble-free performance. To establish a good preventative maintenance program, we suggest the building maintenance man or engineer familiarize himself with these simple rules:

1. The use of specific boiler cleaning compounds cannot be recommended. We do recommend that a reputable firm of water treatment engineers be consulted regarding conditioning boiler water. Proper selection must be made of a compound to prevent damage to copper sheath heating elements.
2. The sight glass should be checked daily to ensure the boiler has adequate water.
3. A monthly inspection should be made of internal wiring. All electrical connections should be checked for tightness. A check for water or steam leaks should also be made and any loose fittings immediately tightened.
4. If boiler is equipped with Solid State Auxiliary Low Water Cutoff, every four months the probe should be checked for deposits and cleaned, if necessary. This is accomplished by removing inspection plate, removing the probe (with a standard sparkplug wrench) cleaning and replacing.

Note: The system will not operate if the boiler is using distilled, demineralized or deionized water. At the same time, one of the bottom heating elements should be removed. If scale has begun to form, all elements should be cleaned and boiler drained and flushed.
5. **IMPORTANT:** The Manufacturers' Data Report enclosed within the instruction sheet is very important and must be put in a safe place. You may be called upon to produce it by a state agency.

INSTRUCTIONS FOR ELEMENT REPLACEMENT READ COMPLETELY BEFORE STARTING WORK

1. Disconnect boiler from electric power supply at main safety switch or fuse panel. Then, turn boiler switch to "off" position.

WARNING: Hazard of Electric Shock, can cause severe personal injury or death. Disconnect power at source before servicing.

WARNING: Hazard of severe personal injury. Allow boiler to cool and pressure to drop to zero before servicing.

WARNING: Provision should be made to prevent water damage from any eventual leaking of boiler or components. Install near a floor drain.

2. On automatic feed units, close valve on incoming water line. Drain boiler completely of water.
3. Open boiler door to expose heating element.
4. Before proceeding with heating element replacement, review causes of element failure on the following page to determine if items other than element replacement need to be serviced.
5. Check that boiler is properly drained. Note wire locations, disconnect wires, and remove failed heating element from the boiler.
6. Boilers with multiple heater elements examine condition of other

elements in the boiler. If heavy solids build-up is evident or elements are distorted, replace all elements effected.

7. Examine heater element bolts. If these are corroded, replace with ASME grade B-7 bolt of equivalent size.
8. Clean flange face on boiler carefully so as to maintain smooth gasket surface.
9. Install gasket over heater element and insert element into boiler. When installing heating element gasket do not use any liquid sealer, etc. Install dry.
10. Shown below is the bolt tightening sequence required when replacing heating elements. All bolts, finger tight, should be sequentially tightened (Fig.1, Fig.2 & Fig.3 on the following page) in two (2) stages. First to 100 In/lb then to a final torque of 200 In/lb.

Sequence

Fig.1 -Eight (8) bolt flange (5-3/4 Sq.)	1-5-3-7-2-4-6-8
Fig.2 -Six (6) bolt flange (4-1/2 Sq.)	1-3-5-6-2-4
Fig.3 -Four (4) bolt flange (2 1/2 Sq.)	1-3-2-4

11. Reconnect wiring to heater element and follow boiler startup procedures. Check that required electrical clearance between terminals is maintained.

Note: Heater element bolts should be retorqued after generator has been operating several hours at working pressure.

WARNING: Retorquing should be done when unit is cold and with power disconnected at source.

12. Open water valve so water supply can reach boiler feed mechanism.
13. Put Main safety switch to "on" position.
14. Turn boiler switch to "on" position.
15. As boiler automatically refills, observe the new flange assembly for possible leaks. If water is noticed, the bolts must be retightened. Before doing this, turn the boiler off at the main fuse safety switch.
16. As boiler is heated to working pressure, check flange assembly again for leaks.

WARNING: Avoid use of chemical cleaning compounds. Follow maintenance instruction.

WARNING: Before installing your new elements, be sure the McDonnell-Miller low-water cut-off is operating perfectly and the float chamber and lower equalizer column are completely clear of sludge or other foreign matter.

Failure to do this may cause the immediate burnout of the new elements.

All elements are thoroughly checked before shipment. The manufacturer cannot be responsible for burnouts caused by a faulty low-water cut-off.

The lower equalizer column can best be examined by breaking the unions on either side and then visually and manually examining the piping with your fingers or probes to see if it is clear and clean.

MAINTENANCE

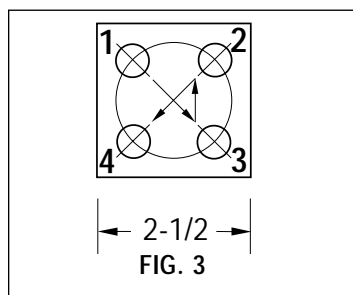
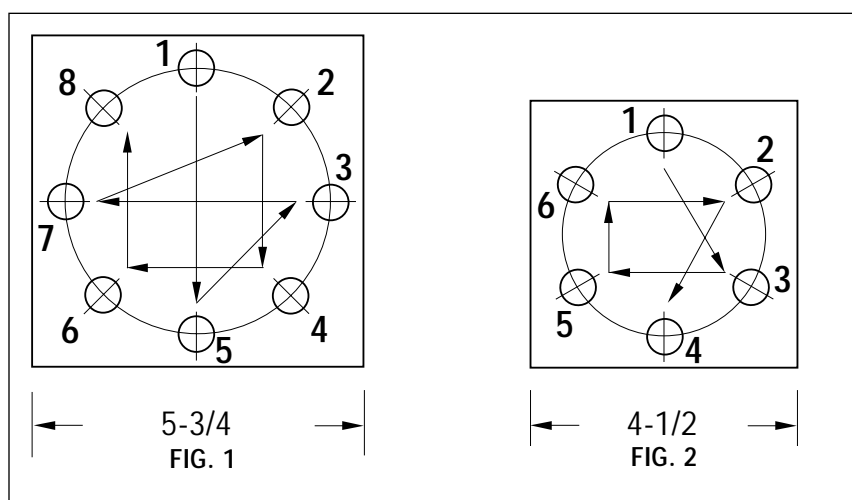
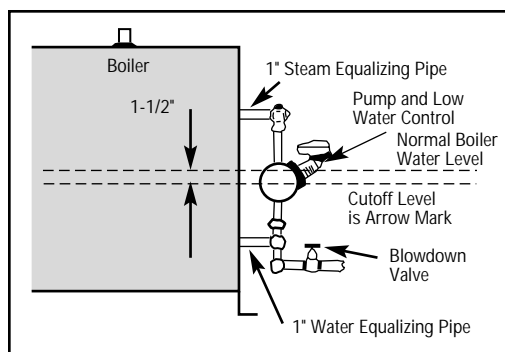

IMMERSION HEATER FAILURE CAUSES

HEATER ELEMENT CONDITION	PROBABLE CAUSE
1. Water leakage at heater flange	<ol style="list-style-type: none"> 1. Heater bolts improperly tightened. Refer to flange tightening instructions. 2. Debris on heater flange or generator flange surface. Clean prior to installation. 3. Heater bolts not retorqued after initial operation. Refer to flange tightening instructions.
2. Water leakage at heater element to flange junction.	<ol style="list-style-type: none"> 1. Faulty weld or braze on element to flange connection or corrosion. 2. Verify water is not exiting through heater terminal. Normally seen in condition #5.
3. Burned wiring connections	<ol style="list-style-type: none"> 1. Loose wire connections. Tighten properly after inspection. 2. High resistance in wire connection due to oxidation. Clean wires before reconnecting to element. Replace if necessary.
4. Heater element has open circuit. (Element looks OK but Ohmmeter check shows infinite resistance).	<ol style="list-style-type: none"> 1. Element has open circuit due to normal wear and tear to end life. 2. If generator is undersized for its application, heaters will be over worked and reach end of life sooner. 3. Element has been overheated due to excessive scale build up. The scale acts as an insulator retarding heat transfer to the water. Short life will result. If significant scale is observed on element, this would indicate need for more frequent blowdown or descaling. 4. Wrong voltage supplied to element. 5. Element not totally immersed in water. This causes a localized hot spot which melts the wire inside the element. Cause of problem is fault in water level control system. Elements damaged in this manner may be distorted. Repair and verify operation of the level control prior to restarting the heater.
5. Heater element has developed a ground fault. When this occurs, a hole may be formed in the sheath material, allowing water to enter the element.	<ol style="list-style-type: none"> 1. Corrosion of heater element sheath-use of corrosive descaler compounds will etch sheath. Use only approved descaler to remove scale. 2. Element has overheated due to excessive scale build up. This can cause localized hot spot which sometimes arcs thru insulation and the ground metal sheath. More frequent blowdown and/or descaling is needed. 3. Element not totally immersed in water. This causes a localized hot spot which produces a hole in sheath. Cause of problem is fault in water level control system. Elements damaged in this manner may be distorted. 4. Excess vibration. Vibration could cause rubbing of elements wearing a hole in the sheath. Vibration could be caused by large machinery nearby. 5. Wrong voltage supplied to element.

RENEWAL PARTS IDENTIFICATION

Part Description	Part Number
GAUGE GLASS ASSEMBLIES, CHECK VALVES & SIGHT GLASSES	
Check Valve 1/2" CES-6 through CES-18	344-118536-053
Check Valve 3/4" CES-24 through CES-180	344-118536-054
Gauge Glass Assembly Valves (O-ring gaskets included)	344-120970-002
Protector Rods (2 required) CES-6 through CES-18	242-121047-008
Protector Rods (2 required) CES-24 through CES-72	242-121047-001
Protector Rods (2 required) CES-100 through CES-180	242-121047-009
O-Ring Gaskets (2 Required)	132-073284-001
Pyrex Glass 2 "O" Ring Gaskets 7 3/4" CES-6 through CES-18	374-121046-011
Pyrex Glass 2 "O" Ring Gaskets 9 3/4" CES-24 through CES-72	374-121046-012
Pyrex Glass 2 "O" Ring Gaskets 11 3/4" CES-120 through CES-100	374-121046-014
SAFETY VALVE	
15 psig 1/2" CES-6 through CES-36	344-300032-001
15 psig 3/4" CES-48 through CES-72	344-300032-017
15 psig 1 1/2" CES-100 through CES-180	344-300032-040
30 psig 1/2" CES-6 through CES-60	344-300032-002
30 psig 3/4" CES-72	344-300032-018
30 psig 1" CES-100 through CES-180	344-300032-035
50 psig 1/2" CES-6 through CES-72	344-300032-003
50 psig 1" CES-100 through CES-180	344-300032-036
100 psig 1/2" CES-6 through CES-72	344-300032-004
100 psig 3/4" CES-160 through CES-180	344-300032-020
PRESSURE CONTROLS & SEQUENCES	
Operating Pressure Controls 10-100 psi	292-300031-001
Hi-Limit Control Manual Reset 90 psi	292-300031-002
5-Step Solid State Sequencer	323-300107-015
10-Step Solid State Sequencer	323-300107-015
Siphon Tube for Pressure Controls	215-300026-002
LOW WATER CUTOFF & PUMP CONTROLS	
MM-150 Control Complete (Auto Reset)	292-300065-001
MM-150M Control Complete (Manual Reset)	292-300065-002
Float and Rod for MM-150 & MM-150M	292-300065-102
Complete Head Mechanism (Auto Reset)	292-300065-100
Complete Head Mechanism (Manual Reset)	292-300065-101
Head Gasket	292-300065-103
3 Wire Cut-off & Alarm Switch (Auto Reset)	292-300065-104
3 Wire Cut-off & Alarm Switch (Manual Reset)	292-300065-105
2 Wire Pump Switch	292-300065-106
Bellows Base Clamp & Bellows Assembly (Auto Reset)	292-300065-108
Bellows Base Clamp & Bellows Assembly (Manual Reset)	292-300065-109
Bellows Base Gasket	292-300065-110
Bellows Base Clamp Assembly (Auto Reset)	292-300065-111
Bellows Base Clamp Assembly (Manual Reset)	292-300065-112
Bellows Base Assembly with Gasket	292-300065-113
CONTROL VOLTAGE TRANSFORMERS (120V SECONDARY)	
1KVA 208V Primary	315-300088-020
1KVA 240/480V Primary	315-300088-021
1 1/2 KVA 208V Primary	315-300088-025
1 1/2 KVA 240/480V Primary	315-300088-026
LOW PRESSURE WATER FEED (ES-99117)	
Solenoid Valve	344-121780-002
Strainer	351-118664-001
CORROSION RESISTANT ELEMENTS & GASKETS	
THREE PHASE	
12kW 208V	155-554735-044
12kW 240V	155-554735-032
12kW 480V	155-554735-015
17kW 208V	155-554735-048
17kW 240V	155-554735-028
17kW 480V	155-554735-016
Gasket	132-146012-011

Part Description	Part Number
COLD WATER INJECTION PUMPS (0-100 PSIG)	
Motor and Pump used in ES-38002	226-300177-001
Motor and Pump used in ES-38020	226-300177-004
Pump only used in ES-38002	226-300173-001
Pump only used in ES-38020	226-300173-004
Motor only used in ES-38002 115V 60Hz	193-300175-001
Motor only used in ES-38002 230V 50Hz	193-300175-002
Motor only used in ES-38020 115V 60Hz	193-300175-004
Strainer used in ES-38020	351-118664-001
V-Band Mount used in ES-38002 & ES-38020	355-300174-001
Solenoid Valve used in ES-38002 & ES-38020	344-121780-002
Hose Assembly 18" Long used in ES-38002 & ES-38020	349-300181-002
Pump Base	015-300125-001
Adapter for Hose used in ES-38002	001-300180-001
Adapter for Hose used in ES-38020	001-300180-002
CONDENSATE RETURN SYSTEMS	
Pump and Motor Assembly used in ES-38083V 26 Gal.	226-300172-003
Pump and Motor Assembly used in ES-38084V 33 Gal.	226-300172-006
Condensate Tank only used in ES-38083V 26 Gal.	226-300218-001
Condensate Tank only used in ES-38084V 33 Gal.	226-300218-002
Parts Common to both 26 & 33 Gal. Systems	
Impeller Raceway for Pump	226-118671-001
Seal for Pump	251-118657-002
"O" Ring	251-118657-003
Float Valve Assembly (Float Valve & Stem)	344-300223-006
Disc Cover Assembly (Less Float Valve)	101-300220-001
Gasket for Disc Cover	132-300224-001
Frame Assembly (Less Tank)	126-300221-001
Strainer 1" NPT	351-118664-019
Gauge Glass Valve Set	344-120970-002
Gauge Glass	374-121046-011
Gauge Glass Protector Rods (2 Required)	242-121047-008
Manual Valve	344-121194-002
Sight Glass Assembly	130-073287-004
Drain Valve	344-121194-006
AUX LOW WATER CUT-OFF (OPTIONAL EQUIPMENT)	
Probe Spark Plug	346-300035-001
Aux Low Water Cut-off Board with Relay	323-300033-016
Aux Low Water Cut-off Board Without Relay	323-300033-017
Relay for Aux Low Cut-off Board	072-300047-003
Probe 7 15/16" CES 6-20	242-300036-019
Probe 9 1/2" CES 24-72	242-300036-002
Probe 10 15/16" CES-100 through CES-180	242-300036-017
MISCELLANEOUS PARTS	
ON-OFF Switch with Pilot Light	292-053223-002
Control Circuit Fuse	128-072576-027
Control Circuit Terminal Block 4 Pole 250V 20AMP	303-075443-003
Control Circuit Fuse Block	129-300029-001
Blank Flange	121-300199-001
Element Gasket	132-146012-011
Stainless Steel Bolts (6 required) for Element	345-072565-428
Vacuum Breaker Assembly	344-300149-001
AUTO BLOWDOWN PARTS	
Motorized Valve 1/2" CES-6 through CES-18	344-300089-002
Motorized Valve 1" CES-24 through CES-180	344-300089-005
Timer	292-300101-002
Relay SPST No. 2	072-300072-002
Relay Interval Delay .6-60 Sec. 3	072-300148-003
Switch Momentary Contact DPDT 4	292-300146-001
Switch Rocker SPDT 5	272-300147-001
Pilot Light Red 6	213-300145-001
Terminal Block 4 Pole	303-075444-003
Terminal Block 5 Pole	303-075444-004
Fuse Block 30A	129-024494-001
Fuse 15A	128-121133-072
Motorized Ball Valve (Size 1/2)	344-300089-001
Motorized Ball Valve (Size 1/2)	344-300089-002
Motorized Ball Valve (Size 1/2)	344-300089-003
Motorized Ball Valve (Size 1)	344-300089-004
Motorized Ball Valve (Size 1)	344-300089-005
Motorized Ball Valve (Size 1)	344-300089-006
HONEYWELL PRESSURE CONTROLS	
Operating Pressure Control 2-15 psi	292-300038-001
Hi-Limit Control (Manual Reset) 15 psi	292-300038-005
Proportional Pressure Control 2-15 psi	292-300039-001
Operating Pressure Control 5-50 psi	292-300038-002
Hi-Limit Control (Manual Reset) 50 psi	292-300038-006
Proportional Pressure Control 2-50 psi	292-300039-002
Operating Pressure Control 10-150 psi	292-300038-003
Hi-Limit Control (Manual Reset) 90 psi	292-300038-007
Proportional Pressure Control 5-150 psi	292-300039-003

RENEWAL PARTS IDENTIFICATION

Part Description	Part Number
VALVES & GAUGES	
1/4" Ball Valve (Pressure Gauge)	344-300323-002
Blowdown Valve 1/2" CES-6 through CES-18	344-121194-006
Blowdown Valve 1" CES-24 through CES-180	344-121194-002
Pressure Gauge 2" 0-160 psi CES-6 through CES-72 (50 and 100 psi trim)	130-118661-001
Pressure Gauge 3 1/2" 0-160 psi CES-100 through CES-180 (50 and 100 psi trim)	130-118661-009
Pressure Gauge 2 1/2" 0-60 psi CES-6 through CES-72 (30 psi trim)	130-118661-003
Pressure Gauge 3 1/2" 0-60 psi CES-100 through CES-180 (30 psi trim)	130-118661-007
Pressure Gauge 2 1/2" 0-30 psi CES-6 through CES-72 (15 psi trim)	130-118661-013
Pressure Gauge 3 1/2" 0-30 psi CES-100 through CES-180 (15 psi trim)	130-118661-006
CONTACTORS	
Fusible Contactors	
30 amps with 35-60 amp 600V block	072-122686-003
40 amps with 35-60 amp 600V block	072-122686-006
50 amps with 35-60 amp 600V block	072-122686-009
Non-fusible Contactors	
60 amp without fuse block	072-047913-016
50 amp without fuse block	072-047913-019
40 amp without fuse block	072-047913-012
30 amp without fuse block	072-047913-020
POWER FUSES AND TERMINAL BLOCKS	
35 amp 600V	128-121138-033
40 amp 600V	128-121133-064
45 amp 600V	128-121133-065
50 amp 600V	128-121133-066
60 amp 600V	128-121133-067
Fuse Block 35-60 amp 60 amp 600V	129-047445-002
Power Terminal Blocks	
3 pole 115 amp 1 line circuit 1 load circuits	303-071809-032
3 pole 175 amp 1 line circuit 4 load circuits	303-071809-012
3 pole 335 amp 1 line circuit 4 load circuits	303-071809-014
3 pole 335 amp 1 line circuit 8 load circuits	303-071809-016
HEATING ELEMENTS — SPECIFY VOLTAGE	
SINGLE PHASE	
12kW 208V	155-554735-004
12kW 480V	155-554735-009
17kW 208V	155-554735-006
17kW 480V	155-554735-011
THREE PHASE	
12kW 208V	155-554735-003
12kW 240V	155-554735-001
12kW 346V	155-554735-012
12kW 380V	155-554735-017
12kW 480V	155-554735-008
17kW 208V	155-554735-005
17kW 240V	155-554735-002
17kW 346V	155-554735-013
17kW 380V	155-554735-018
17kW 480V	155-554735-010
22.5kW 240V	155-554735-021
22.5kW 480V	155-554735-022
22.5kW 550V	155-554735-019

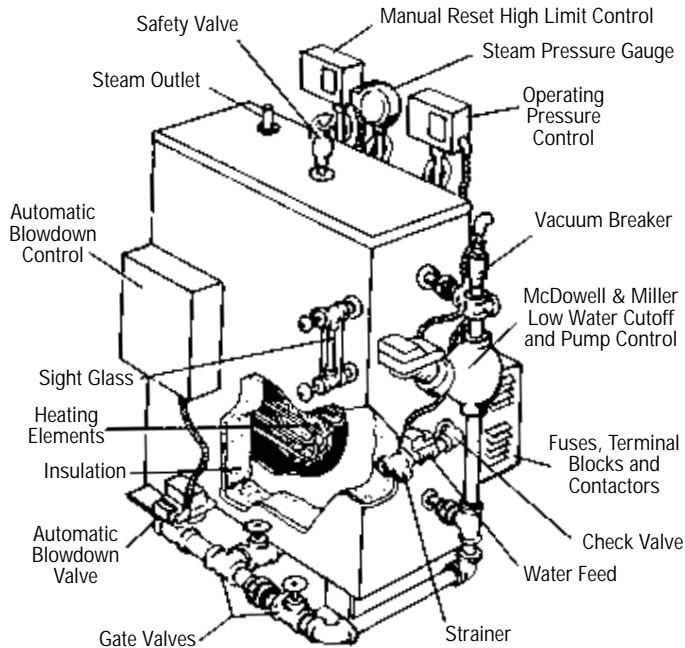

WARRANTY AND LIMITATION OF REMEDY AND LIABILITY

Chromalox warrants only that the Products and parts manufactured by Chromalox, when shipped, and the work performed by Chromalox when performed, will meet all applicable specification and other specific product and work requirements (including those of performance), if any, and will be free from defects in material and workmanship under normal conditions of use. All claims for defective or nonconforming (both hereinafter called defective) Products, parts or work under this warranty must be made in writing immediately upon discovery, and in any event, within one (1) year from delivery, provided, however all claims for defective Products and parts must be made in writing no later than eighteen (18) months after shipment by Chromalox. Defective and nonconforming items must be held for Chromalox's inspections and returned to the original f.o.b. point upon request. THE FOREGOING IS EXPRESSLY IN LIEU OF ALL OTHER WARRANTIES WHATSOEVER, EXPRESS, IMPLIED AND STATUTORY, INCLUDING, WITHOUT LIMITATION, THE IMPLIED WARRANTIES OF MERCHANTABILITY AND FITNESS FOR A PARTICULAR PURPOSE.

Notwithstanding the provisions of this WARRANTY AND LIMITATION Clause, it is specifically understood that Products and parts not manufactured and work not performed by Chromalox are warranted only to the extent and in the manner that the same are warranted to Chromalox by Chromalox's vendors, and then only to the extent that Chromalox is reasonably able to enforce such warranty, it being understood Chromalox shall have no obligation to initiate litigation unless Buyer undertakes to pay all cost and expenses therefor, including but not limited to attorney's fees, and indemnifies Chromalox against any liability to Chromalox's vendors arising out of such litigation.

Upon Buyer's submission of a claim as provided above and its substantiation, Chromalox shall at its option either (i) repair or replace its Products, parts or work at the original f.o.b. point of delivery or (ii) refund an equitable portion of the purchase price. THE FOREGOING IS CHROMALOX'S ONLY OBLIGATION AND BUYER'S EXCLUSIVE REMEDY FOR BREACH OF WARRANTY, AND IS BUYER'S EXCLUSIVE REMEDY AGAINST CHROMALOX FOR ALL CLAIMS ARISING HEREUNDER OR RELATING HERETO WHETHER SUCH CLAIMS ARE BASED ON BREACH OF CONTRACT, TORT (INCLUDING NEGLIGENCE AND STRICT LIABILITY) OR OTHER THEORIES, BUYER'S FAILURE TO SUBMIT A CLAIM AS PROVIDED ABOVE SHALL SPECIFICALLY WAIVE ALL CLAIMS FOR DAMAGES OR OTHER RELIEF, INCLUDING BUT NOT LIMITED TO CLAIMS BASED ON LATENT DEFECTS. IN NO EVENT SHALL BUYER BE ENTITLED TO INCIDENTAL OR CONSEQUENTIAL DAMAGES AND BUYER SHALL HOLD CHROMALOX HARMLESS THEREFROM. ANY ACTION BY BUYER ARISING HEREUNDER OR RELATING HERETO, WHETHER BASED ON BREACH OF CONTRACT, TORT (INCLUDING NEGLIGENCE AND STRICT LIABILITY) OR OTHER THEORIES, MUST BE COMMENCED WITHIN ONE (1) YEAR AFTER THE DATE OF SHIPMENT OR IT SHALL BE BARRED.

W2008M

Chromalox[®]

PRODUCT SERVICE

2150 N. RULON WHITE BLVD., OGDEN, UT 84404

Phone: 1-800-368-2493

WIEGAND INDUSTRIAL DIVISION
EMERSON ELECTRIC CO.

