

SDRA

PDS SDRA

Portable High Temperature Blower Heaters

- **30, 48 and 60kW**
- **102,360 to 204,720 BTUH**
- **480 or 600 Volts Three Phase**
- **Built-in Controls**
- **Air Temperature to 180°F**
- **Use with Flexible Duct**



Description

The Chromalox SDRA SuperDragon is a rugged, self contained, mobile electric blower heater that can be used with or without optional inlet or outlet 20" diameter flexible duct. The SDRA units can be used for comfort heating or process heating temperatures to 180°F, and can be located in an ambient of up to 130°F. The SDRA includes a fan only switch, that allows the unit to be used to recirculate room air, supply fresh air source, or capture fume exhaust. The SDRA heaters provide for easily adjustable airflow for a wide variety of applications including flexible ducting up to 165 feet in length. Each unit includes two thermostats to enable the operator to set the maximum inlet and outlet temperatures, magnetic contactor(s). A 120 volt control transformer, power on pilot lights and a high limit cutout to protect the heater against unintended low air flow conditions. The SDRA can be left unattended without the threat of fire or by-product of combustion from fuel fired heaters. The bright red polyester powder coated heater can be easily moved because of two 10" diameter pneumatic wheels on the front and a 4" lockable swivel castor on the rear.

Construction

Heating Section

A structural frame consisting of 2 spun steel rings and formed steel channels support a 20 gauge steel cylinder phosphate coated for corrosion resistance and finished in red polyester powder coat paint. The cylinder contains patented metal sheath Fintube® heating elements that include industrial grade .475" diameter steel sheath tubular heaters with furnace brazed steel fins for maxi-

mum heat transfer. The elements are firmly attached to a robust steel assembly with steel bulkhead threaded fittings.

Fan Section

The fan assembly includes a 16" tubeaxial fan designed for industrial use and includes a streamlined belt tunnel that isolates the motor, drives and bearings from the air stream. The fan blades are precision balanced made with spark resistant aluminum and includes permanently lubricated ball bearings. Safety belt guards are supplied to protect operating personnel from harm. The drip proof motor is rated 1hp, 3 phase 1,725 rpm and operates on line voltage. Fan speed can be varied from 1,500 to 2,300 RPM for various air flows by use of adjustable pulleys.

Controls

Two adjustable thermostats (60 to 180°F) are located on the heater cylinder to allow the inlet and outlet temperatures to be adjustable for single pass heating or recirculated air temperature control. The power is switched by magnetic contactor(s) which are located in a gasketed NEMA 4 enclosure along with the motor starter, control voltage transformer and heater power fusing. A fan only toggle switch and pilot lights for power and heater are also located in the enclosure.

Safety Guards

Front and rear grills are 10 gauge, finished in black polyester powder coat paint and are designed to meet OSHA requirements.

Chromalox®
PRECISION HEAT AND CONTROL

SDRA - Portable High Temperature Blower Heaters

Applications

- Aircraft Cabin Heating
- Plant Maintenance
- Building Construction Sites
- Curing Plaster and Concrete
- Warming Workers
- Drying After Flood Damage
- Insect Control in Grain Mills
- Thawing Frozen Pipes
- Re-circulating Fresh Air
- Circulating Fresh Air
- Exhausting Contaminated Air



Specifications And Ordering Information

kW	Volts 3 Ph	Amps	BTUH	HP	CFM	Temp. Rise of	Model	Stock	Dimensions (In.)				Wt. (Lbs)
									PCN	W	L	H	
30	480	37.2	102,360	1	1100-2700	35-88	SDRA-30-43	S	295689	26	44	38.5	150
30	600	30.0	102,360	1	1100-2700	35-88	SDRA-30-93	NS	295697	26	44	38.5	150
48	480	58.9	163,776	1	1100-2700	59-141	SDRA-48-43	NS	295700	30.25	44	38.5	160
48	600	47.3	163,776	1	1100-2700	59-141	SDRA-48-93	NS	295718	30.25	44	38.5	160
60	480	73.3	204,720	1	1100-2700	70-172	SDRA-60-43	S	295726	30.25	44	38.5	170
60	600	58.9	204,720	1	1100-2700	70-172	SDRA-60-93	NS	295734	30.25	44	38.5	170

SDRA-RG Series Rental Grade Portable Blower Heater

Two SDRA-RG Stacked

Description

The SDRA-RG series of SuperDragons have the same features as the standard industrial grade units except that they feature a welded aluminum frame for light weight and can be stacked two high to reduce floor space during storage or transportation to various venues. The rental grade units feature 4" diameter casters, two of which lock.

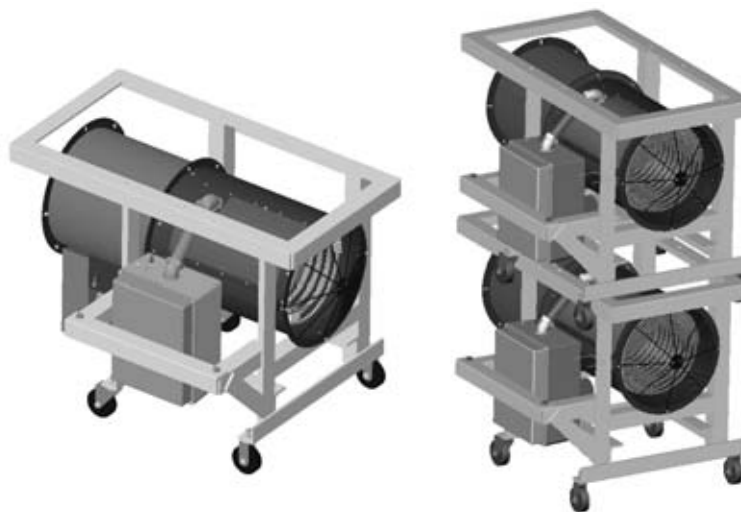

Specifications And Ordering Information

kW	Volts 3 Ph	Amps	BTUH	HP	CFM	Temp. Rise of	Model	Stock	Dimensions (In.)				Wt. (Lbs)
									PCN	W	L	H	
30	480	37.2	102,360	1	1100-2700	35-88	SDRA-30-43RG	NS	295742	35.75	45.75	34.5	150
30	600	30.0	102,360	1	1100-2700	35-88	SDRA-30-93RG	NS	295750	35.75	45.75	34.5	150
48	480	58.9	163,776	1	1100-2700	59-141	SDRA-48-43RG	NS	295769	35.75	45.75	34.5	160
48	600	47.3	163,776	1	1100-2700	59-141	SDRA-48-93RG	NS	295777	35.75	45.75	34.5	160
60	480	73.3	204,720	1	1100-2700	70-172	SDRA-60-43RG	NS	295785	35.75	45.75	34.5	170
60	600	58.9	204,720	1	1100-2700	70-172	SDRA-60-93RG	NS	295793	35.75	45.75	34.5	170

SDRA - Portable High Temperature Blower Heaters

SDRA Portable High Temperature Blower Heaters (cont'd.)

Model DRA-CC ChromaCube Portable Heating System for Use with Customer Supplied Air Source

Description

The DRA-CC series of SuperDragons have the same construction features as the rental grade units except do not include the blower section. The units require customer supplied air via 20" diameter flexible duct. The control circuit includes an air flow switch to protect the heater in case of a restricted or loss of air flow. The control enclosure includes a contactor(s), control transformer, power fusing and power on pilot lights.



Two DRA-CC Stacked

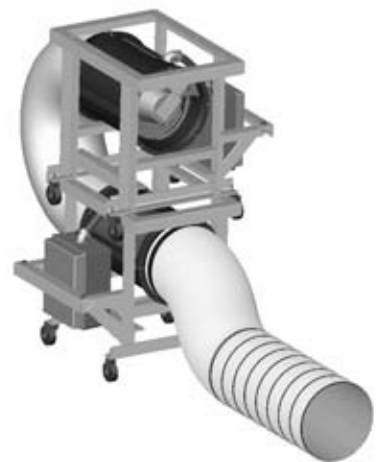

Specifications And Ordering Information

kW	Volts 3 Ph	Amps	BTUH	CFM	Temp. Rise oF	Model	Stock	PCN	Dimensions (In.)			Wt. (Lbs)
									W	L	H	
30	480	36.1	102,360	1100-2700	35-88	SDRA-CC-30-43	NS	295806	35.75	45.75	34	115
30	600	28.9	102,360	1100-2700	35-88	SDRA-CC-30-93	NS	295814	35.75	45.75	34	115
48	480	57.8	163,776	1100-2700	59-141	SDRA-CC-48-43	NS	295822	35.75	45.75	34	125
48	600	46.2	163,776	1100-2700	59-141	SDRA-CC-48-93	NS	295830	35.75	45.75	34	125
60	480	72.2	204,720	1100-2700	70-172	SDRA-CC-60-43	NS	295849	35.75	45.75	34	135
60	600	57.8	204,720	1100-2700	70-172	SDRA-CC-60-93	NS	295857	35.75	45.75	34	135

SDRA - Portable High Temperature Blower Heaters

Accessories



AD-16 Adjustable Damper

The adjustable damper can be attached to the intake side of the SuperDragon heaters to reduce the amount of airflow to insure the required air temperature is realized. This is especially important when the unit will be used without flexible duct.

Model	Description	Stock	PCN	Wt (lbs)
AD-16	Adjustable Damper	S	295902	12



Duct Adapter Ring

Provides a means to attach 20" flexible duct to the intake or outlet of the SuperDragon series heaters. Two are required if using duct on the inlet and outlet for applications where air is recirculated.

Model	Description	Stock	PCN	Wt (lbs)
DAR-20	20" Duct Adaptor	S	295873	20

FX-20 Flexible Duct

Chromalox heavy duty, flexible duct is constructed of 100% polyester based fabric and is 20" diameter and 25' long. It is made to resist wear and is suitable for temperatures from -40 to 220°F. The duct is internally supported with a steel wire helix and can be used on the air intake end of the heater and will not collapse under the negative pressure.



Model	Description	Stock	PCN	Wt (lbs)
FX-20	20" Dia. Flexible Duct 25'	S	295865	45

Flexible Duct Splice

The flexible duct splice is designed to splice two or more 25' lengths of flexible duct to create longer lengths.



Model	Description	Stock	PCN	Wt (lbs)
FDS-20	20" Dia. Duct Splice Kit	S	295881	40

Duct Clamp (not shown)

Stainless steel band is designed to fit over the flexible duct for a secure attachment to the adapter ring or flexible duct splice.

Model	Description	Stock	PCN	Wt (lbs)
DC-20	20" Dia. Duct Clamp	S	295890	3

Performance Data – Temperature Rise

30 kW "SDRA"										
Duct Length	1500 RPM			1800 RPM			2200 RPM			
	CFM	ΔT	ΔT w/AD-16*	CFM	ΔT	ΔT w/AD-16*	CFM	ΔT	ΔT w/AD-16*	
0	1750	53°F	72-82°F	2220	42°F	50-56°F	2680	35°F	39-43°F	
25	1610	58°F	81-88°F	2100	44°F	61-69°F	2250	37°F	49-54°F	
40	1500	62°F	Insufficient cfm	1960	48°F	69-75°F	2390	39°F	56-58°F	
50	1410	66°F		1925	48°F	74-79°F	2200	43°F	Insufficient cfm	
65	1325	70°F		1800	52°F	80-81°F	1950	48°F		
75	1200	78°F		1650	56°F	Insufficient cfm	1750	53°F		
90	1125	82°F		1410	66°F		1620	57°F		
100	1080	86°F		1300	78°F	1600	58°F			
115	Insufficient cfm			1200	72°F	Insufficient cfm				
125				1150	81°F					
150				1110	84°F					
160				1090	86°F					

Note: Add an additional 15' of duct for each 90° bend and 25' of duct for each 180° bend. Example: 50' of duct with a 90° bend and a 180° bend would be equal to a straight section of duct 90' long.

* Temperature rise with AD-16 Adjustable Damper installed.

48 kW "SDRA"										
Duct Length	1500 RPM			1800 RPM			2200 RPM			
	CFM	ΔT	ΔT w/AD-16*	CFM	ΔT	ΔT w/AD-16*	CFM	ΔT	ΔT w/AD-16*	
0	1750	85°F	115-131°F	2220	67°F	80-90°F	2680	59°F	62-69°F	
25	1610	93°F	130-141°F	2100	71°F	98-110°F	2250	59°F	78-86°F	
40	1500	99°F	Insufficient cfm	1960	77°F	110-120°F	2390	62°F	90-93°F	
50	1410	106°F		1925	78°F	118-126°F	2200	69°F	Insufficient cfm	
65	1325	112°F		1800	83°F	128-130°F	1950	77°F		
75	1200	125°F		1650	91°F	Insufficient cfm	1750	86°F		
90	1125	131°F		1410	106°F		1620	91°F		
100	1080	138°F		1300	115°F	1600	93°F			
115	Insufficient cfm			1200	124°F	Insufficient cfm				
125				1150	130°F					
150				1110	134°F					
165				1090	138°F					

Note: Add an additional 15' of duct for each 90° bend and 25' of duct for each 180° bend. Example: 50' of duct with a 90° bend and a 180° bend would be equal to a straight section of duct 90' long.

* Temperature rise with AD-16 Adjustable Damper installed.

60 kW "SDRA"										
Duct Length	1500 RPM			1800 RPM			2200 RPM			
	CFM	ΔT	ΔT w/AD-16*	CFM	ΔT	ΔT w/AD-16*	CFM	ΔT	ΔT w/AD-16*	
0	1750	106°F	144-164°F	2220	84°F	100-112°F	2680	70°F	78-86°F	
25	1610	116°F	Insufficient cfm	2100	88°F	122-138°F	2250	74°F	98-108°F	
40	1500	124°F		1960	96°F	138-150°F	2390	78°F	112-116°F	
50	1410	132°F		1925	96°F	148-158°F	2200	84°F	Insufficient cfm	
65	1325	140°F		1800	104°F	160-162°F	1950	96°F		
75	1200	156°F		1650	112°F	Insufficient cfm	1750	106°F		
90	1125	164°F		1410	132°F		1620	116°F		
100	1080	172°F		1300	144°F	1600	116°F			
115	Insufficient cfm			1200	156°F	Insufficient cfm				
125				1150	162°F					
150				1110	168°F					
165			1090	172°F						

Note: Add an additional 15' of duct for each 90° bend and 25' of duct for each 180° bend. Example: 50' of duct with a 90° bend and a 180° bend would be equal to a straight section of duct 90' long.

* Temperature rise with AD-16 Adjustable Damper installed.

Maximum Outlet 180°F
Minimum Airflow 1070 CFM

PDS SDRA
March 2003