

Circulation Heater Systems

ASME & Custom Engineering Specifications *(cont'd.)*

Form PE307

Customer Name: _____ Reference: _____ Date: _____

Page 1 of 2

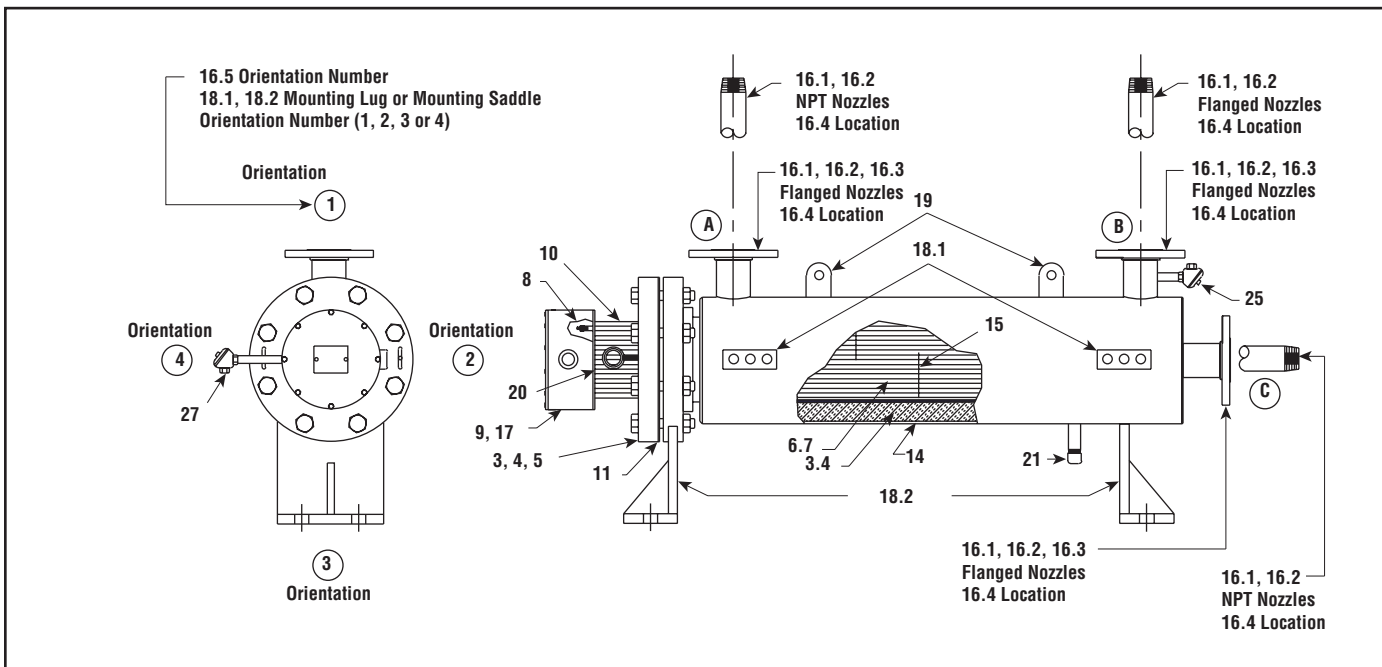

Note — Drawing is for Illustration Purposes Only. The flange size, number of heating elements, terminal enclosure configuration etc., will vary according to options selected.

<i>Operating Conditions</i>		<i>4. FLANGE AND VESSEL MATERIAL:</i>	
1. HEATED MEDIUM:		<input type="checkbox"/> Carbon Steel	<input type="checkbox"/> Carbon Steel-Galvanized
2. TEMPERATURE IN:	°F	TEMPERATURE OUT:	°F
3. FLOW RATE:	SCFM or GPM or Lbs/Hr or	<input type="checkbox"/> Other (Specify)	
4. OPERATING PRESSURE:		5. FLANGE RATING:	
psig.		<input type="checkbox"/> Class 150 <input type="checkbox"/> Class 300 <input type="checkbox"/> Other (Specify)	
5. DESIGN TEMPERATURE:		6. HEATING ELEMENT WATT DENSITY:	
°F Max. °F Min.		<input type="checkbox"/> 6.5 W/In ² <input type="checkbox"/> 15 W/In ²	
6. DESIGN PRESSURE:		<input type="checkbox"/> 23 W/In ² <input type="checkbox"/> 45 W/In ² <input type="checkbox"/> Other (Specify)	
7.		7. HEATING ELEMENT SHEATH MATERIAL:	
<input type="checkbox"/> Indoor <input type="checkbox"/> Outdoor		<input type="checkbox"/> Steel <input type="checkbox"/> Copper <input type="checkbox"/> 304 Stainless Steel	
8. HAZARDOUS AREA ENVIRONMENT:		<input type="checkbox"/> 316 Stainless Steel <input type="checkbox"/> INCOLOY®	
Class Div. Group		<input type="checkbox"/> Other (Specify)	
9. AMBIENT TEMPERATURE:		8. TERMINAL SEALS:	
°F		<input type="checkbox"/> Yes <input type="checkbox"/> No	
<i>Heater Specifications (Check All That Apply)</i>		<input type="checkbox"/> Silicone Resin (450°F) <input type="checkbox"/> Silicone Fluid (500°F)	
1. RATING:		<input type="checkbox"/> RTV (450°F) <input type="checkbox"/> Epoxy (250°F)	
Volts Phase Kilowatts		<input type="checkbox"/> Hermetic (Maximum 1000°F Sheath Temperature)	
2. NUMBER OF ELECTRICAL CIRCUITS:		<input type="checkbox"/> Other (Specify)	
<input type="checkbox"/> Standard <input type="checkbox"/> Other: No. of Circuits kW/Circuit		9. TERMINAL ENCLOSURE:	
3. NOMINAL FLANGE & VESSEL SIZE/NO. HEATING ELEMENTS:		<input type="checkbox"/> General Purpose	
<input type="checkbox"/> 3"/3 <input type="checkbox"/> 6"/12 <input type="checkbox"/> 8"/18		<input type="checkbox"/> Moisture Resistant <input type="checkbox"/> Explosion Resistant	
<input type="checkbox"/> 10"/27 <input type="checkbox"/> 12"/36 <input type="checkbox"/> 14"/45		10. TERMINAL ENCLOSURE STANDOFFS:	
<input type="checkbox"/> 16"/72 <input type="checkbox"/> 18"/108 <input type="checkbox"/> Other (Specify)		<input type="checkbox"/> Yes <input type="checkbox"/> No	
		<input type="checkbox"/> 4" <input type="checkbox"/> 6" <input type="checkbox"/> Other (Specify)	
		11. BODY FLANGE GASKET:	
		<input type="checkbox"/> Standard <input type="checkbox"/> Spiral Wound <input type="checkbox"/> Other (Specify)	

Circulation Heater Systems

ASME & Custom Engineering Specifications *(cont'd.)*

Form PE307

Page 2 of 2

Customer Name: _____ Reference: _____ Date: _____

Heater Specifications *(Check All That Apply)*

12. ASME DESIGN and CERTIFIED: <input type="checkbox"/> Yes Section _____					23. ELECTRONIC PROCESS TEMPERATURE CONTROL MOUNTED ON HEATER: <input type="checkbox"/> Yes <input type="checkbox"/> No a) <input type="checkbox"/> General Purpose <input type="checkbox"/> Moisture Resistant <input type="checkbox"/> Explosion Resistant					
13. ELECTRICAL CODES: National Electrical Code <i>(Standard)</i> <input type="checkbox"/> UL Listed <input type="checkbox"/> CSA Certified <input type="checkbox"/> Other <i>(Specify)</i> _____					24. MECHANICAL PROCESS TEMPERATURE HIGH LIMIT PROTECTION CONTROL MOUNTED ON HEATER: <input type="checkbox"/> Yes <input type="checkbox"/> No a) <input type="checkbox"/> General Purpose <input type="checkbox"/> Moisture Resistant <input type="checkbox"/> Explosion Resistant b) Temperature Range (°F) <input type="checkbox"/> 0 - 100 <input type="checkbox"/> 60 - 250 <input type="checkbox"/> 200 - 550 <input type="checkbox"/> 300 - 700					
14. THERMAL INSULATION: <input type="checkbox"/> None <input type="checkbox"/> Standard <input type="checkbox"/> High Temperature <input type="checkbox"/> Weatherproof Jacket					25. PROCESS THERMOCOUPLE IN OUTLET: a) <input type="checkbox"/> Yes <input type="checkbox"/> No <input type="checkbox"/> Type J <input type="checkbox"/> Type K b) With Separate Terminal Box <input type="checkbox"/> None <input type="checkbox"/> General Purpose <input type="checkbox"/> Moisture Resistant <input type="checkbox"/> Explosion Resistant					
15. CIRCULATION: <input type="checkbox"/> Unbaffled <input type="checkbox"/> Baffled										
16. NOZZLE SIZE, TYPE and ORIENTATION: <input type="checkbox"/> No Standard or as Indicated Below					26. ELECTRONIC HIGH LIMIT PROTECTION CONTROL MOUNTED ON HEATER: <input type="checkbox"/> Yes <input type="checkbox"/> No a) <input type="checkbox"/> General Purpose <input type="checkbox"/> Moisture Resistant <input type="checkbox"/> Explosion Resistant					
Nozzles	1. Size	2. Type	3. Rating	4. Location						5. Orientation
Inlet										
Outlet										
Notes: 16.1 Size is Nominal 16.2 Type is NPT threaded or raised Face Flange 16.3 Rating is 150 Lb. 300 Lb. etc. if Flanged 16.4 Location is A, B or C (from Figure) 16.5 Orientation is 1, 2, 3 or 4 (from Figure)					27. OVERHEAT THERMOCOUPLE ON HEATING ELEMENT SHEATH: a) <input type="checkbox"/> None <input type="checkbox"/> Type J <input type="checkbox"/> Type K b) With Separate Terminal Box <input type="checkbox"/> None <input type="checkbox"/> General Purpose <input type="checkbox"/> Moisture Resistant <input type="checkbox"/> Explosion Resistant					
17. MOUNTING POSITION: <input type="checkbox"/> Vertical-Terminal Box <input type="checkbox"/> Up <input type="checkbox"/> Down <input type="checkbox"/> Horizontal										
18. MOUNTING METHOD: <input type="checkbox"/> Standard or as Indicated Below 18.1 <input type="checkbox"/> Mounting Lugs-Orientation Number 18.2 <input type="checkbox"/> Mounting Saddles-Orientation Number Notes: Orientation Number is 1, 2, 3 or 4 (from Figure)					28. SKID MOUNTED CIRCULATION HEATER SYSTEM COMPLETE WITH CONTROL PANEL WIRED TO HEATER: a) <input type="checkbox"/> Yes <input type="checkbox"/> No b) <input type="checkbox"/> Vertical Orientation <input type="checkbox"/> Horizontal Orientation c) Control Panel <i>(Attach Detail Requirements)</i>					
19. LIFTING LUGS on HEATER PIPE BODY: <input type="checkbox"/> Yes <input type="checkbox"/> No 20. LIFTING LUGS on HEATER FLANGE: <input type="checkbox"/> Yes <input type="checkbox"/> No 21. DRAIN PIPE-3/4" NPT: <input type="checkbox"/> Yes (Horizontal Mount) <input type="checkbox"/> No										
22. MECHANICAL PROCESS TEMPERATURE CONTROL MOUNTED ON HEATER: <input type="checkbox"/> Yes <input type="checkbox"/> No a) <input type="checkbox"/> General Purpose <input type="checkbox"/> Moisture Resistant <input type="checkbox"/> Explosion Resistant b) Temperature Range (°F) <input type="checkbox"/> 0 - 100 <input type="checkbox"/> 60 - 250 <input type="checkbox"/> 200 - 500 <input type="checkbox"/> 300 - 700 <input type="checkbox"/> Other <i>(Specify)</i> _____					29. Other SPECIAL FEATURES: 30. MODEL NUMBER: _____ _____ _____ _____					

STEAM, AIR AND GAS