



## Strip & Ring Heaters

### Selection & Installation Guidelines

- Utility Clamps
- Milled Plates
- Clamping Bands
- Oven Mounting

#### Installation Guidelines

Chromalox strip elements, in most cases, can be applied with standard hardware. However, for firm contact and best heat transfer, stocked Chromalox clamps are recommended.

**Note** — Heat insulating material should not be placed against the sheath of the heating element

#### Utility Clamps

**Utility Clamps** secure strip elements to flat surfaces or surfaces with large radii such as large tanks. Threaded studs are welded to surface, heaters are positioned, then clamps are bolted down. Where more than one clamp is used, tighten nuts and then back off 1/2 turn to allow for expansion.

#### Utility Clamps

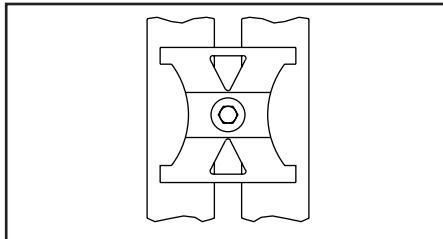

#### Milled Plates

**Milled Plates** allow heaters to be held in position in platens and similar objects with a steel plate recessed to heaters width, thickness and positions, then screwed to the working plate or surface.

#### Milled Plates

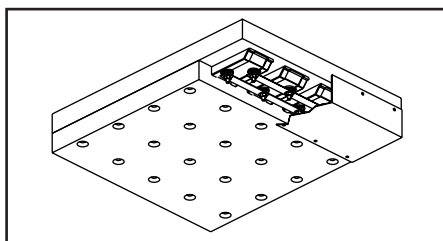

#### Clamping Bands

**Clamping Bands** can be used to firmly fasten strips longitudinally to large diameter cylindrical surfaces.

**Connecting Lead Wires** — Should be nickel-plated copper, nickel or alloy. Copper will oxidize and loosen connections. Do not use copper terminal lugs. See Accessories in this section.

#### Clamping Bands

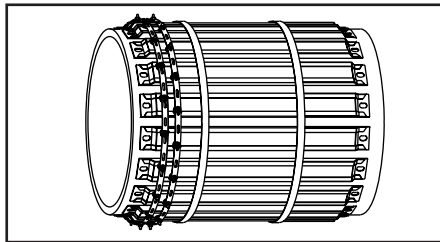

#### Oven Mounting

**Oven Mounting** — Application of strip elements to ovens may be made simply with the use of welded-on studs and secondary insulation bushings. Mounting holes in tabs are slotted to allow for expansion. Refer to Modifications in this section.

#### Oven Mounting

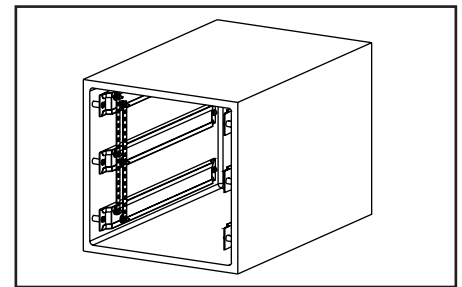

#### Selection Guidelines

Product To Be Heated	Temperature Desired for Products	Sheath Material	Product Temp. (°F)	Allowable Watt Density (W/In <sup>2</sup> )		
<b>Solids</b>						
Molds, Platens, Dies, Pipes, Tanks	Up to 1400°F Clamp-On Applications	Rust-Resisting Iron	560 150	3 8		
		Chrome Steel	850 700 400	7 10 15		
			INCOLOY® <sup>1</sup>	200 750 1100 1350 1400	28 20 8 3 2.5	
				<b>Air &amp; Gases</b>		
		Free Air Velocity- 1 ft/sec.	Up to 1400°F Bracket Mounted	Rust-Resisting Iron	500 100	3 8
				Chrome Steel	950 800 500	7 10 15
INCOLOY® <sup>1</sup>	1400 400				3 34	
Free Air Velocity- 4 ft/sec.	Up to 1400°F Bracket Mounted	Rust-Resisting Iron	500 250	3 8		
		Chrome Steel	1000 850 550	7 10 15		
			INCOLOY® <sup>1</sup>	1400 600	5 34	

Note: <sup>1</sup>CSA Only

## Strip & Ring Heaters

### Modifications

#### *Lengthwise Bending*

**Lengthwise Bending** for clamping around pipes or cylindrical vessels. Terminals may be located inside or outside of curvature for all types listed.

**3" Min. Inside Radius** — Type S, SE, OT PT, TH, NH, SNH, SN and ST.

**6" Min. Inside Radius** — Type SSE, SSEM, SSNH and SSNHM.

**4-3/4" Min. Inside Radius** — Type WS.

#### *Lengthwise Bending*

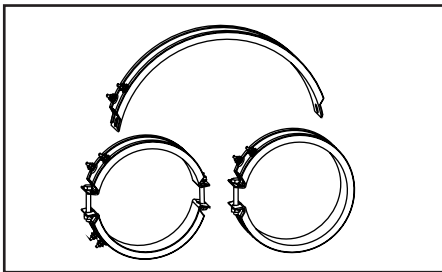

#### *Cross-Section Curving*

**Cross-Section Curving** — Type SE only, for clamping strips to 2, 2-1/2, 3, 4, 6, 8 and 12" pipes. For larger size pipe, use flat strips. Radii available 1-3/16, 1-7/16, 1-3/4, 2-1/4, 3-5/16, 4-5/16 and 6-5/16" and 8-3/4". Terminals outside only.

#### *Cross-Section Curving*

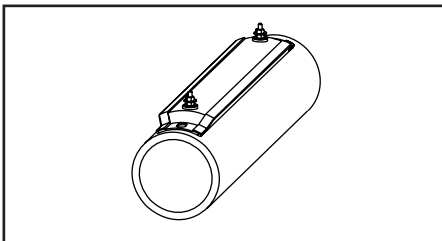

**Special Lengths** — Type PT, SE, SN and SNH only. Special lengths are made-to-order for instances in which the amount of heat applied to a surface is critical and standard lengths are not suitable.

**Special Voltage and Wattage** — All types. Certain highly specialized applications may require special ratings. However, most can be handled with standard heaters or standard ratings applied on an alternate voltage. Contact your Local Chromalox Sales office.

**Special Wattage Distribution** — All types except TH. When even temperatures are required and end losses may cause an unsatisfactory temperature drop near the edges, additional wattage can be provided at each end of the strip to make up for losses.

**Dual Contact Surface** — Type SE only. 53-7/8" maximum A dimension. Flush-top construction gives good contact for all surfaces of the strip heater. Ideal for use in machined slots and installing between two smooth metal surfaces.

#### *Without Mounting Tabs*

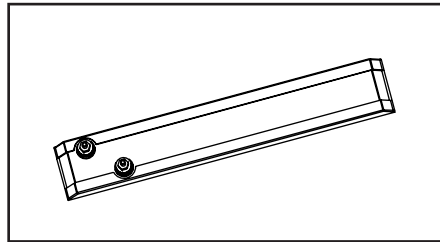

**Without Mounting Tabs** — All types. Permits installing more heat in a given confined space. Specify "without mounting tabs" when ordering this feature.

**Extra Strong Mounting Tabs** — All types except WS. Recommended when strips are bent lengthwise and tabs are used for bolting.

**Monel® Sheath** — Type S, SE, OT, PT, HSP and WS.

**Stainless Steel Sheath** — All types.

#### *Cover for Seamless Strips, Factory Welded*

**Cover for Seamless Strips with Threaded Opening for Conduit** — Cover is welded to heater. Specify position of threaded opening either on top of cover, or as shown. Type SSE, SSEM and SSNHM.

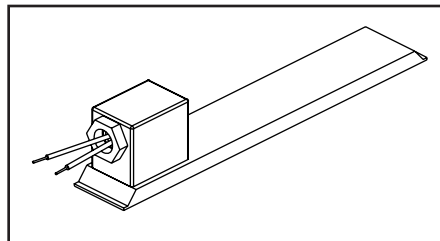

#### *Fahnestock® Terminals*

**Fahnestock® Terminals** — Type S only. For quick temporary connections where ambient temperatures do not exceed 150°C. Maximum recommended amperage is 7.5 Amps.

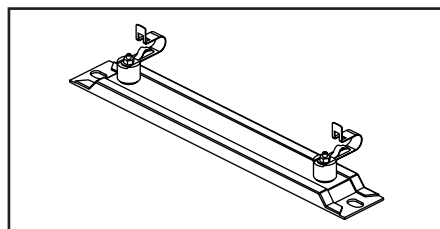

**Special Length Terminals** — All types. Where a shorter or longer terminal bolt than standard shown in drawing is needed, indicate length needed.

#### *Rubber-Molded Terminals*

**Rubber-Molded Terminals** — Type NS only. Used generally in low temperature applications where moisture, condensation and high humidity are considerations. Available in neoprene-rubber (to 190°F). Longer cold end or lower wattage is required to assure temperature limit of molding material is not exceeded. End opposite terminal is welded closed.

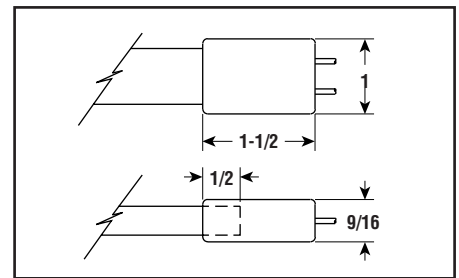

#### *Special Lead Wire Terminal Construction*

**Special Lead Wire Terminal Construction** — All types. Specified most often when clearance is unavailable for standard terminals and when lead wires are more suitable for wiring to nearby components.

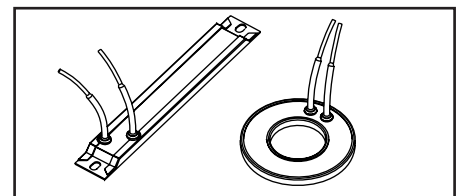

#### *Secondary Insulation Bushing*

**Secondary Insulation Bushings** — All Types except NS. Must be used when strips are mounted for air heating only or when connected in series on line voltages 480V or above. **Note** — To accommodate bushings, a 17/32 x 11/16" diameter mounting hole in tabs should be specified for heaters. To Order — Specify PCN 255716 (includes bushing and hardware for one strip) and quantity.

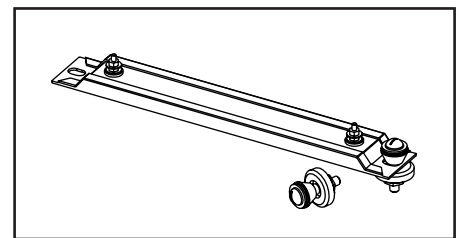

## Strip & Ring Heaters

### Accessories

- Protective Terminal Covers
- Shims
- Ceramic Post Terminal Insulators
- Porcelain Hi-Temp Insulation

**Protective Terminal Covers** — Types OT, PT, SE, WS and Seamless Types SSE, SSEM, SSNH and SSNHM. Helps guard terminals from spillovers, dripping. Removable sheet-metal cover, with Bx fitting, is shipped separately.

#### OT-AC-1 (PCN 129242)

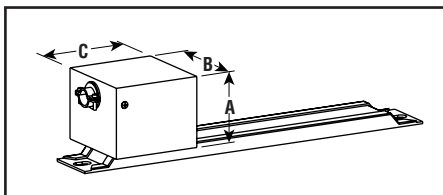

#### PT-AC-1 (PCN 255724)

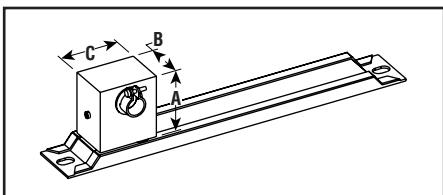

#### SE-AC-1 (PCN 256727)

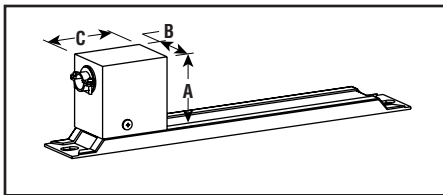

#### Protective Terminal Covers

Model	Dimensions (In.)		
	A	B	C
OT-AC-1	2	2-1/2	2-1/2
PT-AC-1	1-7/8	1-1/8	1-3/4
SE-AC-1 <sup>1</sup>	2-1/16	1-1/2	2

1. Used on type WS (mounted sideways).

#### Shims

**Shims** — Types OT, PT, S, SE and TH. Provide same advantage as flush-top construction and can be used with stock heaters. Shims are 0.031" thick, 29/32" wide and lengths to fit heater.

#### Shims

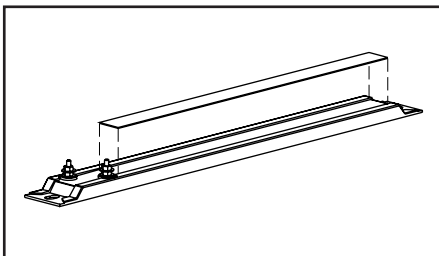

#### Ceramic Post Terminal Insulators

**Ceramic Post Terminal Insulators** — All types except NS and SN. Use with insulated wire to help protect against electrical shock. Wires can leave terminal at any angle.

#### Ceramic Post Terminal Insulators

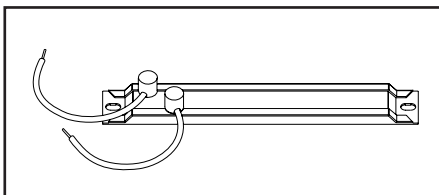

PCN 259805 (Nickel plated steel hardware)  
PCN 255732 (Stainless steel hardware)

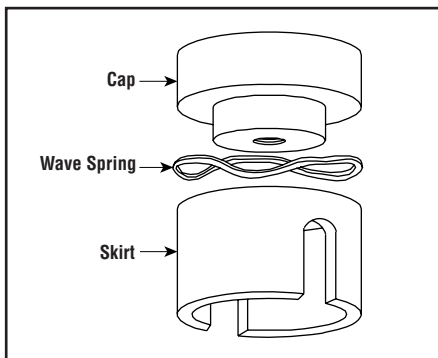

#### Porcelain Beads

Bead Size	Dimensions (In.)			Wire Size Solid	No. Beads Per Ft.	No. Beads (Pieces)	PCN
	A	B	C				
2	0.17	0.068	0.17	14 B&S	88	4,535	263880
3	0.2	0.092	0.2	12 B&S	69	2,900	263900
4	0.26	0.156	0.26	8 B&S	51	1,500	263927
5	0.33	0.124	0.33	10 B&S	45	650	263943
6	0.4	0.156	0.4	8 B&S	38	360	263960

**To Order**—Specify PCN and quantity.

#### Porcelain Hi-Temp Insulation

##### Porcelain Hi-Temp Insulation —

For insulating buss bars spec. 51 porcelain insulators 1/2 L x 13/16" W with 1/8 x 9/16" slot. 95 pieces per lb.

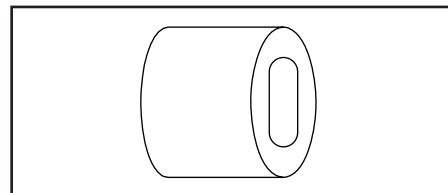

**To Order** — Specify pounds, PCN 269780 and porcelain insulators.

**For Insulating Bare Wires** — Two types available:

1. **Porcelain Tubing** — 3/8" O.D. x 1/8" I.D. x 6" L (may be broken for shorter lengths). Suitable for 10-gauge or smaller; 8-gauge takes No. 6 porcelain bead.

**To Order** — Specify quantity and PCN 263863.

#### Porcelain Tubing

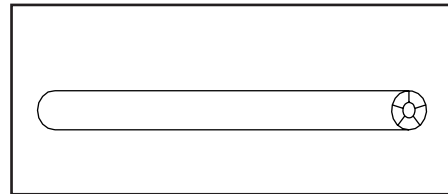

2. **Porcelain Beads** — Listed in table below. Can be used when wiring does not permit straight tubing.

#### Porcelain Beads

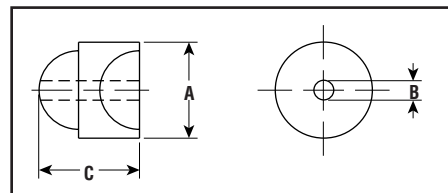

3. When selecting porcelain beads for stranded wire, use next larger gauge wire and use bead for that size (i.e., 10 gauge stranded wire requires a No. 6 bead).

## Strip & Ring Heaters

### Wire & Accessories

(cont'd.)

- High Temperature (Bare) Wire
- Insulated Wire
- Buss Bar
- Silicone Boot Termination Kit
- Silicone Boot Termination Kit with Thermostat

**Ambient Temperature Corrections for Insulated Wires** — Multiply ampacity values, in tables below, by the following correction factors to determine current-carrying capacity at higher ambient temperatures.

Ambient Temp.	Nickel-Plated Copper Teflon® Insulated	Nickel		
		Silicone Glass	Teflon® Glass	MGS-Mica Glass
°C	°F			
30	86	—	—	1.36
50	122	0.98	0.97	0.98
60	140	0.95	0.94	0.95
70	158	0.93	0.9	0.93
80	176	0.9	0.87	0.9
90	194	0.87	0.83	0.87
100	212	0.85	0.79	0.85
120	248	0.79	0.71	0.79
140	284	0.72	0.61	0.72
149	300	0.65	0.5	0.65
177	350	0.58	0.35	0.58
204	400	0.49	—	0.49
232	450	0.35	—	0.35
260	500	—	—	0.87
269	550	—	—	—
300	572	—	—	0.7

**Note** — After exposure to high temperatures, all wire insulation becomes brittle and will not withstand repeated flexing.

### Wire & Buss Bar

High-temperature wire and buss bar are recommended for connections to heater terminals and for runs in heated zones. When ambient temperature exceeds maximum allowed for insulated wire, use bare wire or buss bar with porcelain insulators. Current-carrying capacities should be carefully noted.

Buss bar is solid or perforated to facilitate wiring, especially when terminals are in line. Perforated buss bar, has 11/32 x 7/32" slots on 7/16" centers. When connecting elements with buss bar, provide expansion loops between elements. Buss bars may be used in multiples for higher ampacity (approx. 33-1/2% per buss bar) than listed above, center.

### High Temperature (Bare) Wire

Size AWG	Solid/S Strand/F	Ampacity <sup>1</sup>	Nom. O.D.	Model	PCN
<b>550°F Max. Wire Temp. Nickel-plated Copper, Uninsulated</b>					
14	S	41	.064	CSB-14	263839
10	S	70	.102	CSB-10	263812
8	S	93	.128	CSB-8	263804
<b>1000°F Max. Wire Temp. Manganese-nickel, Uninsulated</b>					
14	F	12	.075	AFB-14	269317
14	S	12	.064	ASB-14	269309
12	F	15	.097	AFB-12	269296
12	S	15	.081	ASB-12	269288
10	F	20	.12	AFB-10	269270
10	S	20	.102	ASB-10	269261

**To Order** — Specify PCN and quantity.

### Insulated Wire

Size AWG	Solid/S Strand/F	Ampacity <sup>1</sup>	Nom. O.D. Insul. In.	Model	PCN
<b>392°F Max. Wire Temp. Type A Nickel Wire Silicone Rubber Treated Glass Braid Insulated 600V UL Listed</b>					
16	F	27	.224	3-CFI-16	263759
16	S	27	.224	3-CSI-16	263740
14	F	36	.237	3-CFI-14	263732
14	S	36	.237	3-CSI-14	263724
12	F	45	.263	3-CFI-12	263716
12	S	45	.263	3-CSI-12	263708
10	F	60	.29	3-CFI-10	263695
10	S	60	.29	3-CSI-10	263687
<b>482°F Max. Wire Temp. Type TGT, Nickel-plated Copper, Teflon® Impregnated Glass Braid Insulated 600V UL Listed</b>					
14	F	39	.121	6-CFI-14	263791
14	S	39	.112	6-CSI-14	295398
12	F	54	.141	6-CFI-12	263783
12	S	54	.13	6-CSI-12	295400
10	F	73	.17	6-CFI-10	263775
10	S	73	.156	6-CSI-10	295419
8	F	93	.212	6-CFI-8	263767

**482°F Max. Wire Temp. Teflon® Tape and Silicone Impregnated Glass Braid Insulated 600V UL Listed**

14	F	39	.121	3-AFI-14	269253
12	F	54	.141	3-AFI-12	269237
10	F	73	.17	3-AFI-10	269210

**842°F Max. Wire Temp. Nickel-clad Copper, MGS-Mica Glass Insulated 600V**

16	F	33 <sup>1</sup>	.065	6-CFIM-16	295355
14	F	44 <sup>1</sup>	.102	6-CFIM-14	295363
12	F	55 <sup>1</sup>	.118	6-CFIM-12	295371

**To Order** — Specify PCN and quantity.

1. See note 1 in Buss Bar Table.
2. These wiring recommendations are general in nature. Confirm actual wire size and selection in accordance with NEC (National Electrical Code).

### Buss Bar

Buss Bar Monel	DIM (In.)		Ampacity <sup>1</sup>	PCN
	Width	Thick		
<b>700°F Max. Wire Temp. Solid</b>				
	0.5	.032	18	346124
	0.5	.064	28	346132
<b>Perforated Slot Size = 7/32 Dia.</b>				
	0.5	.032	9	346140
	0.5	.064	16	346159

**To Order** — Specify PCN and number of feet.

1. These current values will cause the conductor to operate at 100°F above surrounding ambient. Values may also be used for bare wire with porcelain tubes or bead insulation. Monel max. limit is 800°F.



### Silicone Boot Termination Kit

**SBK** — The silicone boot termination kit provides electrical insulation for strip heater terminals and leads with ring type insulated connector on one end for bringing power to the strip heaters.

### Silicone Boot Termination Kit with Thermostat

**SBKT** — The silicone boot termination kit with thermostat used with strip heaters provides an inexpensive way to maintain temperature in control cabinets, panels and other small enclosures. In this application, strip heaters are used to prevent freezing and corrosion, and to control humidity in enclosures with humidity sensitive electronic components.

Model	PCN	Temperature (°F)	
		Closes	Opens
SBKT-1	386011	38	53
SBKT-2	386020	60	75
SBKT-3	386038	105	120
SBK	121890	N/A	N/A

### SBKT

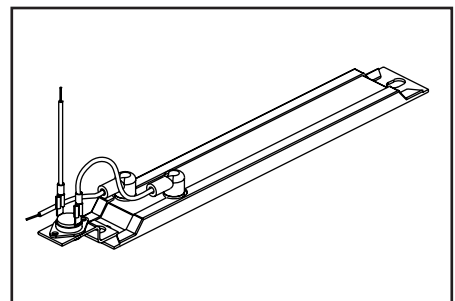

## Strip & Ring Heaters Accessories (cont'd.)

- Element Clamps
- Clamping Bands
- Mounting Studs

### Element Clamps

Cast-iron clamps, for use with Chromalox strip and ring elements, retain their strength at elevated temperatures to assure maximum sheath-to-surface contact. Resulting uniform efficient heat transfer from internal resistance wire to the heated material minimize hot spots on the element, contributing to long service life.

**Clamp 6018** — Usually used in sets of two or more to clamp ring elements to flat surfaces. 5/16" flathead machine screws are normally used with head brazed or welded to work surface (PCN 263978).

### Clamp 6018

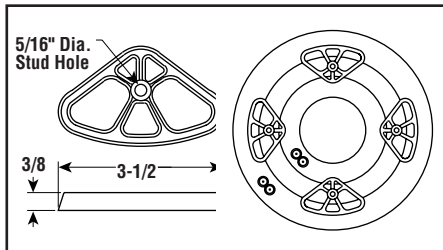

**Clamp 5971** — Use to clamp two strip heaters on 2" centers using 5/16" studs spaced 5" apart (PCN 263636).

### Clamp 5971

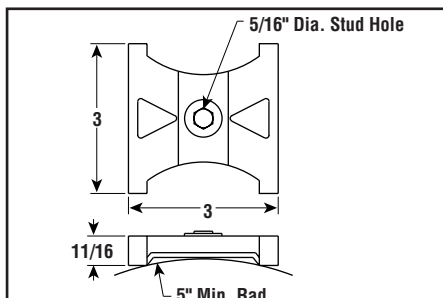

**Clamp 6933** — Use to clamp two strip heaters on 3" centers using 3/8" studs at 5" intervals (PCN 263644).

### Clamp 6933

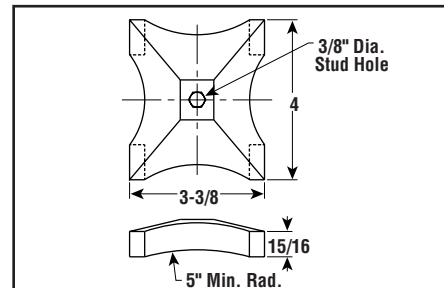

**Clamp 5970** — Use to clamp three strip heaters on 2" centers using 5/16" studs at 5" intervals (PCN 263652).

### Clamp 5970

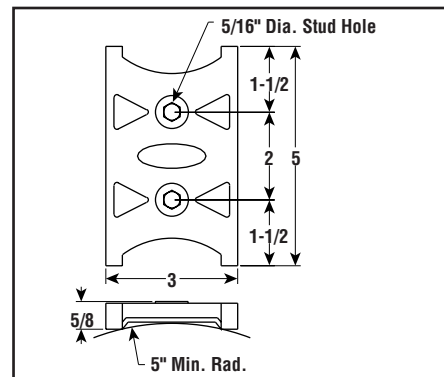

### Clamping Bands

**Type SC Clamping Bands** — Provide permanently tight fit on cylinders, nozzles, pipes and other round surfaces. Stainless steel band with alloy screw. For small pipe diameters, strip elements should have cross-section curving (see Modifications in the Components section).

**For Most Satisfactory Results**, bands should be spaced about 5 inches apart and should be drawn up tight to assure good contact between heater or thermostat bulb and surface.

### Clamping Bands (type SC)

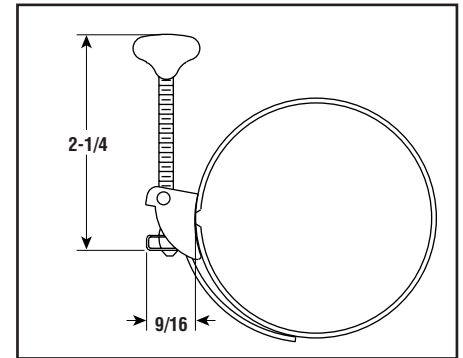

### Clamping Bands

Max. Pipe Dia. (In.)	Model	Stock	PCN
6-1/8	SC-820-20	S	265340
7-1/8	SC-820-22	S	265359
9-1/8	SC-820-26	S	265367
11-1/8	SC-820-30	S	265375
14-1/8	SC-820-34	S	265383
16-1/8	SC-820-36	S	265391
20-1/8	SC-820-40	S	265404
26-1/8	SC-820-46	S	265412

To Order — Specify PCN and quantity.

### Mounting Studs

**Mounting Studs** — For use with Chromalox clamps. For all clamps except No. 6933, studs are 5/16" — 18 x 1-1/2" Monel® (PCN 127845), steel washer (PCN 127853), Monel® nut (PCN 127861). For No. 6993 clamp; studs are 5/16" — 18 x 2" Monel® (PCN 127837).

**Installation** — Fasten studs to the work surface by welding, brazing or threading. Use correct size stud to fit clamp. See Selection & Installation Guidelines in the Components section. For temperatures over 750°F, stainless steel studs are recommended.

**Note** — When tightening nuts, torsion should not exceed 10 foot pounds maximum. Heaters must be allowed to expand. One center clamp should hold heater. Nuts on other clamps should be backed off approximately 1/2 turn to allow for heater expansion.