

Packaged Systems Overview

- Heat Transfer Systems
- Large Tank Immersion Heaters
- Steam and Hot Water Boilers

Applications

Chromalox Packaged Systems are safe, versatile and easy to use heating systems for commercial and industrial applications. Pre-engineered and constructed with carefully matched components, the systems provide easy installation and trouble-free operation in the end user's application.

Heat Transfer Systems — Chromalox Packaged Heat Transfer Systems come complete with integral controls and can be used to heat and pump hot or cold fluids such as water, water-glycol solutions and a wide variety of heat transfer fluids including Dowtherm®, Therminol® and Syltherm® 800. Optional cooling modules are available.

Large Tank Heating Systems — Chromalox Packaged Large Tank Heating Systems are uniquely designed to heat large storage tanks located above or below ground and containing highly viscous fluids or heat sensitive materials.

Steam & Hot Water Boilers — Chromalox Packaged Electric Steam and Hot Water Boilers are safe and versatile heat sources that produce low or high pressure steam or hot water for commercial and industrial processes and for comfort heating applications. Chromalox electric boilers can be used anywhere steam is required and electric power is available. They are packaged units that operate from existing distribution voltages, making installation simple.

Application Engineering

The Chromalox sales and service organization has the technical capabilities and equipment to satisfy virtually any heating or heating and cooling requirement. To assist you in calculating requirements for the more common pro-

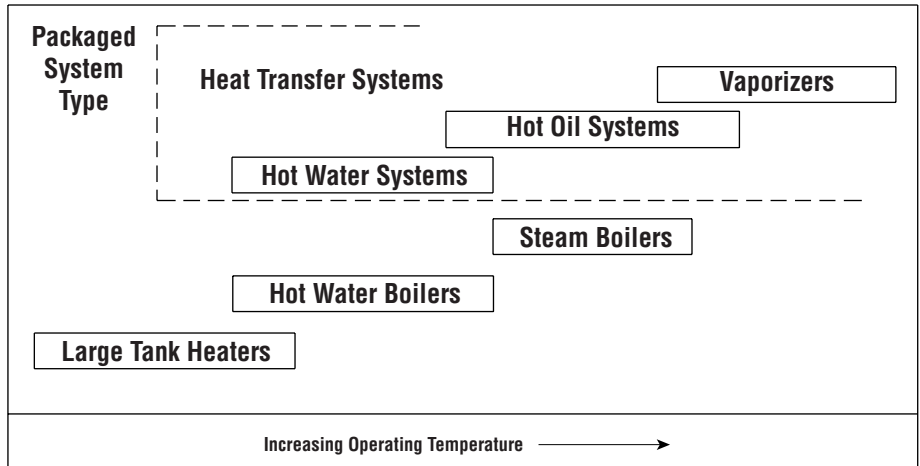

cess applications, we use three computerized heat loss programs:

- Platen Mold and Die Heating Calculations
- Jacketed Vessel Heating Calculations
- Roll Heating Calculations.

All work is performed in the strictest confidence. The Chromalox organization is the most experienced and diversified manufacturer in the electric heating business. Whatever your heating requirements, you can depend on the technical know-how of your Chromalox field representatives. Backed by highly skilled engineers and modern manufacturing facilities, Chromalox field sales engineers can help determine your requirements and provide you with high quality equipment, properly selected, sized and applied.

Note — The Chromalox sales organization can provide its customers with heat loss calculations, design layouts and equipment recommendations as a courtesy and on a no-charge basis. Neither Chromalox or its factory representatives assume any liability for the final selection, suitability or performance of the heating equipment in the end application, except as defined in our published equipment warranty at the back of this catalog.

Standards & Specials

Chromalox has many standard and stock units which will fit many of the more common heating applications. However, Chromalox customers are not limited to "Standards". Chromalox specializes in designing systems to match specific process requirements and a special system designed for your unique application. Some of the more common special requirements include special ratings, sizes and configurations such as a multiple zone systems where each zone is an independent system of heating and cooling sections mounted on a common base.

Hundreds of other options are available including solid state temperature controllers with proportional or relay output, solid state sequencers, timers, alarms, solid state power controllers (SCR's), recorders, programmable controllers or recorders with digital communications linked to your computer or distributed process system (DPS).

Heat Transfer Systems

Application & Selection Guidelines

- Indirect Heating
- Packaged Systems
- Water and Water/Glycol Systems
- Non-Pressurized and Pressurized Heat Transfer (oil) Systems
- Vaporizers

Applications

Chromalox Heat Transfer Systems are used in process heating applications requiring closely controlled process temperatures. Systems are furnished complete with heaters, controls, pumps, valves and necessary plumbing and are used with:

Jacketed Vessels and Tanks — containing waxes, paraffin, exotic chemicals including those having exothermic reactions, hot melt adhesives, resins, varnishes, paints, dyestuffs, molasses, vegetable oils and many other chemical or petrochemical products.

Heated Rolls — for coating paper and paper products, spot carbonizing, vinyl bonding, bonding with hot melt adhesives, calendering and laminating.

Heat Exchangers — for corrosive and noncorrosive fluids.

Platens, Dies and Molds — for laminating wood and plastics, forming of carbon products, epoxy materials and Fibreglas®, plastics extrusion, injection molding, molding rubber and plastic materials: vinyl bonding and bonding with hot melt adhesives.

Pipeline Tracing — of viscous materials such as paints, fuel oils, asphalt and many other chemical and petrochemical products for anti-freeze protection and/or maintaining pumping temperatures.

Industrial Systems — such as snow melting, comfort heating and hot water supply and as standby equipment for industrial and commercial applications in case the supply of other fuels is curtailed.

Simplified Heat Transfer System

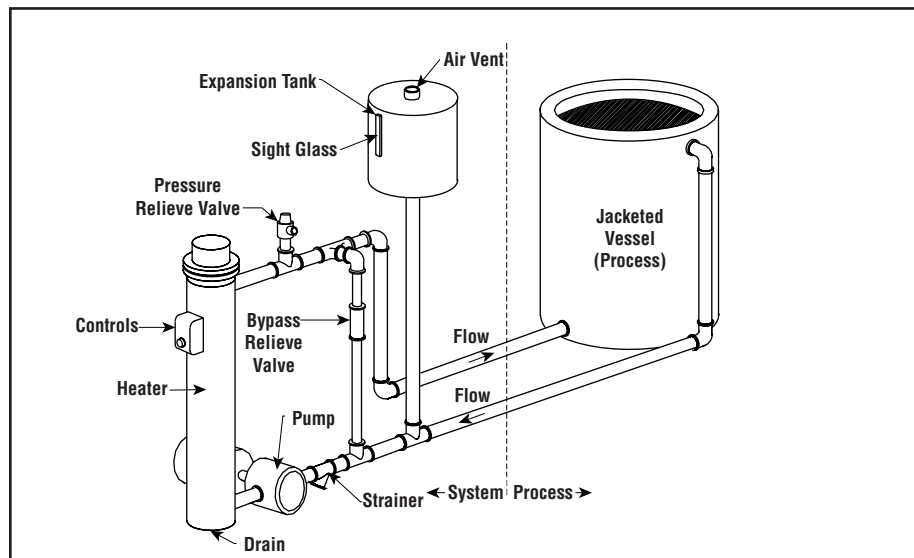

Selection Guidelines

Chromalox Packaged Heat Transfer Systems can supply from 4 to 600 kW of heat energy at up to 750°F operating temperatures. The package selection is usually based on the operating temperature of the heated process (tank, rolls, platens, molds) and the heat energy requirements (kW) to maintain that temperature. Consult the Technical section to calculate the heat energy requirements or contact the nearest Chromalox Sales office for assistance.

When temperature and energy requirements are known, the recommended model of packaged heat transfer system can be estimated from the following Selection Guidelines. Further definitions and specifications follow on the next page.

Heat Transfer — Selection Guidelines

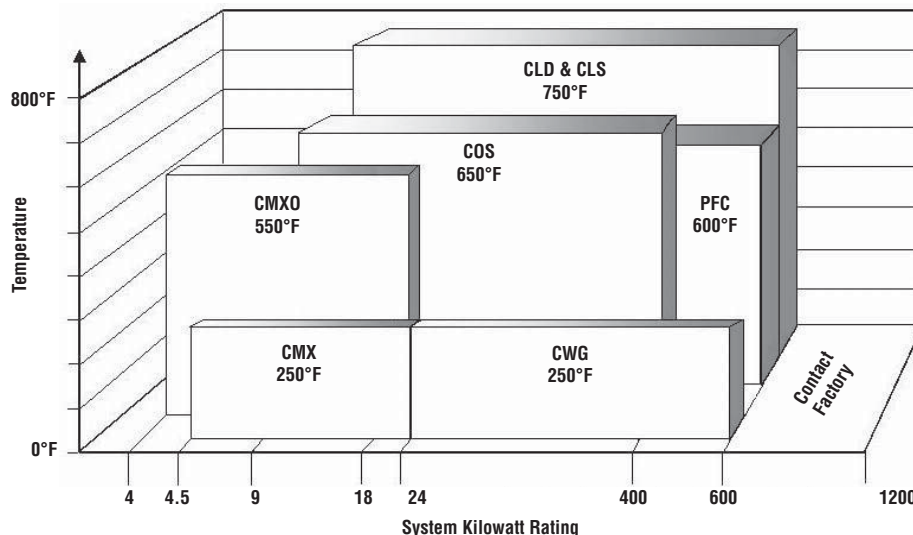

Note — Higher Kilowatt and Vapor Systems also available. Contact your Local Chromalox Sales office.

Heat Transfer Systems Application Data

Heat Transfer Systems can be categorized (grouped) by the type of fluid used in transferring the heat to the process. Water and Water/Glycol systems can be used for temperatures up to 250°F. Special heat transfer fluids and oils can operate up to 750°F and the fluid vaporizer systems utilize vapor phase heat energy to give a higher heat of 750°F with lower operating pressures (150 psig).

The Reference Guidelines and General Specifications give more information to help your selection. Detailed product information appears in the following pages.

Benefits & Advantages

Reliable and Proven Designs — Backed by more than 80 years of engineering and manufacturing of electric heating equipment, Chromalox electric fluid heat transfer systems are safe, versatile and easy to use, pre-engineered heating or heating and cooling systems which operate at existing distribution voltages (208 - 600 Volts).

Safe and Reliable Electrical Wiring — All wiring complies with the National Electrical Code.

Heat Transfer Systems — Reference Guidelines

Heat Transfer Fluid	Operating Pressure (psig)	Operating Temp. (°F)	Maximum kW ¹	Model	Page
Water	Atmospheric	250	24	Systems CMX CWG	D-4
	Atmospheric	250	600		D-5 D-6
Oil	Atmospheric	550	24		Systems CMXO COS-B PFC
	Atmospheric	650	400	D-8	
	Atmospheric	600	600	D-9 D-11	
Oil/Pressurized	150 200	750 750	600 600	CLD-A CLS-A	
Vapor	50	750	300	CHTV	D-21
System Options					D-17
Ordering Information					D-22
1. Higher kW ratings available. Contact your Local Chromalox Sales office.					

Heater Burnout Protection — Every heating chamber has an overtemperature cutout which will de-energize the heater in case of an over-temperature condition.

Matched Components — All Chromalox standard and special systems are pre-engineered with correctly sized and matched components such as pumping rate versus pipe line size, amperage draw versus electrical parts to ensure total system performance.

Optional Controls — All Chromalox heat transfer systems are available with the latest state-of-the-art solid state controls. These include microprocessor-based, recording and SCR power controllers that can control fluid temperatures to $\pm 1^\circ\text{F}$. For a complete selection of optional controls refer to the Controls section.

Heat Transfer Systems — General Specifications

Model	System Type	Application	Operating Temp. (°F)	kW ²	Mbh ⁵	Max. Operating Pressure	ASME	Pressure Rating & Construction	Connection Type
CMX	Mold Temperature Controller	Water/Glycol	50 - 250 ¹	4.5 - 24	15.3 - 81.8	Atmospheric	N/A ³	125 Lb. Threaded	NPT
CWG	Heat Transfer Non-Pressurized	Water/Glycol	50 - 250 ¹	6 - 600	20.5 - 2,047	Atmospheric	Optional	150 Lb. Welded	NPT
WMHTS ⁴	Heat Transfer Multiple Zone	Water/Glycol	50 - 250 ¹	6 - 1,200	20.5 - 4,094	125 psig	Optional	150 Lb. Welded	NPT or Flanged
CMXO	Heat Transfer Non-Pressurized	Heat Transfer Fluid/Oil	50 - 550	6 - 24	20.4 - 81.9	Atmospheric	N/A ³	125 Lb. Welded	NPT
COS	Heat Transfer Non-Pressurized	Heat Transfer Fluid/Oil	50 - 650	9 - 400	30.7 - 1,365	Atmospheric	Optional	150 Lb. Welded	150 Lb. Flanged
PFC	Heat Transfer Non-Pressurized	Heat Transfer Fluid/Oil	50 - 600	9 - 600	30.7 - 2,047	Atmospheric	Optional	150 Lb. Welded	150 Lb. Flanged
CLD	Heat Transfer Pressurized	Heat Transfer Fluid/Oil	50 - 750	9 - 600	30.7 - 2,047	150 psig	Standard	300 Lb. Welded	300 Lb. Flanged
CLS	Heat Transfer Pressurized	Syltherm [®] 800	100 - 750	9 - 600	30.7 - 2,047	200 psig	Standard	300 Lb. Welded	300 Lb. Flanged
OMHTS ⁴	Heat Transfer Multiple Zone	Heat Transfer Fluid/Oil	50 - 750	9 - 1,200	30.7 - 4,094	200 psig	Optional	300 Lb. Welded	300 Lb. Flanged
CHTV	Heat Transfer Vaporizer	Dowtherm [®] Therminol [®]	-20 - 750	15 - 300	51.2 - 1,024	150 psig	Standard	300 Lb. Welded	300 Lb. Flanged

1. Indicates standard design and pressure. Models available to 300°F.
2. Indicates standard design kW. Higher kW ratings available.
3. N/A indicates not available or not applicable.
4. Contact your Local Chromalox Sales office.
5. Mbh is the ASME & ANSI standard for one thousand British Thermal Units per hour.

Other Notes — Use these selection guidelines as a reference to the availability of Chromalox Packaged Heat Transfer and Large Tank Heater Systems. If you cannot find a system with all of the features required for your application, contact your Local Chromalox Sales office.

Water Systems Technical & Application Data

- Water and Water/Glycol Solutions to 250°F
- 4.5 - 400 kW (15 - 2,047 Mbh)
- 208 - 575V, Three Phase
- Non-Pressurized or Atmospheric 125 Lb (CMX) and 150 Lb (CWG) Welded Steel Construction
- Heavy Duty 0.430 Dia. INCOLOY® or 0.475 Copper Elements
- Cast Iron Bronze Fitted Centrifugal Pumps
- Electronic Digital Temperature and Process Controls
- NEMA 1 Electrical Enclosure (STD) - NEMA 4 and 12 Explosion Resistant (Class I, Group D, Div. I) Available on CWG Systems
- Integral Power Panels with Mechanical (CWG) or Mercury (CMX) Contactors
- ASME Pressure Relief Valve
- ASME Section IV or VIII Certification Available on CWG Systems
- Optional Open or Closed-Loop Cooling Modules
- Optional Expansion Tank

Note — Mbh is ASME & ANSI standard for one thousand British Thermal Units per hour.

Typical CWG Water Heat Transfer Piping Schematic

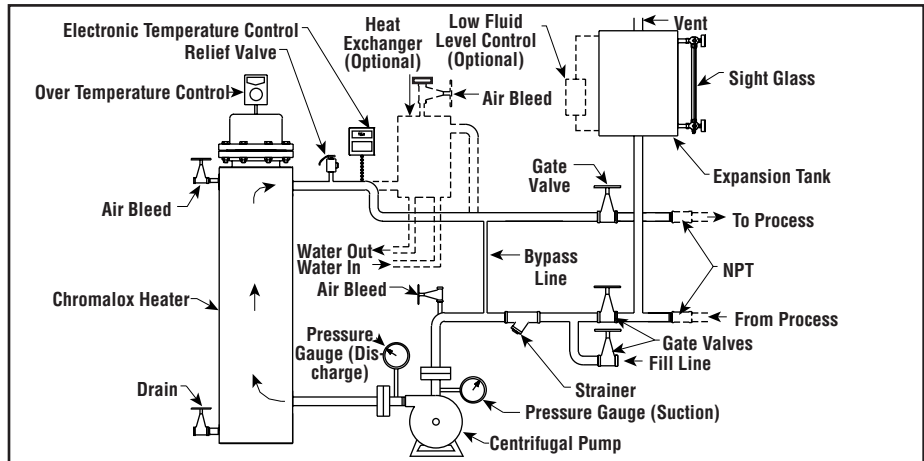

Applications

Chromalox Water Heat Transfer Systems are used in process heating applications requiring closely controlled process temperatures. Systems are furnished complete with heaters, controls, pumps, valves, safety devices and necessary plumbing. They are used with injection molding machines and equipment, jacketed vessels, pipelines, heat tracing and other industrial or commercial processes. Water heat transfer systems can be used for special comfort heating applications.

Advantages

The primary advantage of using water as the heat transfer fluid is its low cost and availability. Water has a high specific heat and is an excellent heat transfer medium. In addition, water usually requires no special handling or disposal procedures.

Heating & Cooling Simplicity

Heating water is relatively simple and straight forward. Cooling can be incorporated into most water heat transfer applications by the simple addition of either open-loop or closed-loop cooling.

Open-Loop Cooling is the least expensive and the easiest to install. It requires makeup water during the cooling cycle which may be a disadvantage in locations with a limited water supply, or hard water.

Closed-Loop Cooling is usually more expensive initially than open-loop cooling, but has the advantage of reusing and conserving water. A cooling tower or refrigerated system is recommended.

Cooling Options

In open-loop cooling, hot water is circulated normally in the closed loop of the process piping. When the temperature of the fluid rises over the controller setpoint, an automatic solenoid valve opens allowing cool water to be injected into the process loop from the primary water supply. Excess hot water is discharged to the drain.

Open-Loop Cooling System

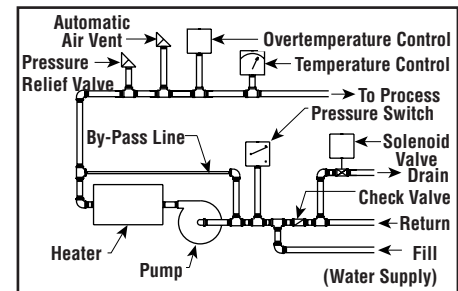

Closed-loop cooling uses a heat exchanger with water from a cooling tower or refrigerated system. Water is recirculated and conserved. No water is discharged down the drain.

Closed-Loop Cooling System

